

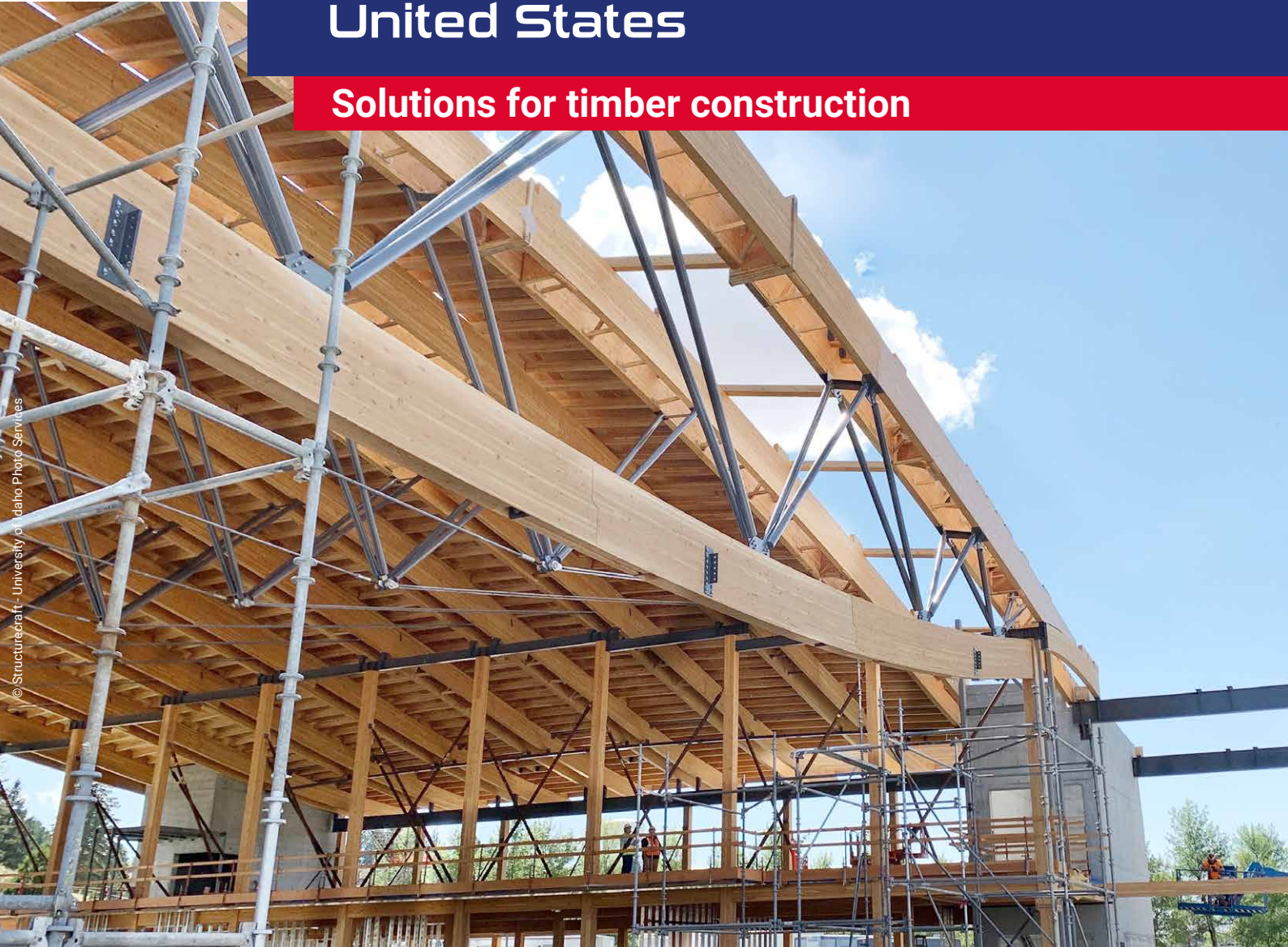

Design Guide United States

Solutions for timber construction



© Structurecraft - University of Idaho Photo Services





SCAN THE QR CODE TO RECEIVE THE DESIGN
GUIDE US IN DIGITAL FORM

Disclaimer

The provided values of this document are based on the expert reports that serve as the basis of the revision of the ICC-ESR-4549 for RAPID® Wood-drilling Screws. Therefore, this version of the US Design Guide anticipates the publication of the report. This includes values for $SG_{NDS} = 0.50$ and LVL of Douglas Fir according to ESR-1040, as well as adaptations for withdrawal capacity allowing to consider the bearing capacity of the screw tips, even for $SG_{NDS} = 0.42$. All included contributions and illustrations in this document are for general information purposes. Schmid Schrauben Hainfeld aims to provide the information correctly, completely and in line with state-of-the-art design methods. This document provides the user with several information for RAPID® Wood-drilling Screws only. It is the responsibility of the user to evaluate if what listed in this document is applicable to the specific design case under evaluation. However, Schmid Schrauben Hainfeld doesn't assume any liability for the content of this document and cannot give warranties of any kind, neither for any direct or consequentially loss or damage caused by mistakes in the design. Reliance on the content of this document and references to the same are strictly at the user's risk. Please contact the authors with any feedback in case of errors or new findings. All included contributions and illustrations are protected by copyright. Without the explicitly expressed permission of the editor, any usages other than those allowed by the copyright law are strictly prohibited and will lead to legal prosecution.

Published 2024, all rights reserved.

IMPRINT

Schmid Schrauben Hainfeld GmbH
Landstal 10, 3170 Hainfeld, Austria
T +43 (0)2764 2652
F +43 (0)2764 3149
E info@schrauben.at
www.schmid-screw.com



About us

With more than 180 years of experience in Austria, Schmid Schrauben Hainfeld is one of Europe's technology leaders in screw production and fastening solution.

Originally founded as a nail and scythe factory, the potential of wood construction screws was recognized early on. Today, we produce high-tech screws for timber constructions with around 150 employees.

Compared to conventional wood screws our self-tapping RAPID® screws are optimized in material properties and geometry. We offer a high performing fastener and reliable product, which is based on our profound

knowledge of the forging trade. Building of all shapes and sizes are built with screws of Schmid Schrauben Hainfeld and confirm the high quality and durability.

Our mission and vision drive us to always deliver the best solutions and push the boundaries of what is possible in fastening technology. With focus on innovation, quality and sustainability, we are ready to actively shape the future and are a reliable partner for our worldwide customers from timber construction industry, timber design engineers and qualified handcraft.

Approvals:



Our self-tapping screws received our first German national technical approval in 1999.



We switched to the European Technical Approval system (ETA-12/0373) in 2012.















Our RAPID® screws have been ICC-ES certified (ESR-4549) since 2023.

Content



About RAPID® screws

RAPID® screws	6
Applications RAPID® partial thread	11
Applications RAPID® fullthread	12
Comparable terms	14
Instruction notes to designers and professionals	16
Adjusted design values	17
Minimum spacing and distance	18
Further geometry requirements	20
Spacing and distances, CLT	21
Metal/wood connections	22
Screw production	24
Corrosion resistance & intended application	25

Technical values RAPID® partial thread

1/4" RAPID® countersunk head		26
5/16" RAPID® countersunk head		28
3/8" RAPID® countersunk head		30
1/2" RAPID® countersunk head		32
1/4" RAPID® washer head		34
5/16" RAPID® washer head		36
3/8" RAPID® washer head		38
1/4" RAPID® SuperSenkFix		40
5/16" RAPID® SuperSenkFix		42
3/8" RAPID® SuperSenkFix		44
5/16" RAPID® Dual		46
3/8" RAPID® Dual		48
1/2" RAPID® Dual		50

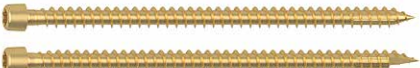
Technical values RAPID® fullthread

5/16" RAPID® fullthread countersunk head		52
3/8" RAPID® fullthread countersunk head		56
1/2" RAPID® fullthread countersunk head		60
5/16" RAPID® fullthread cylinder head		64
3/8" RAPID® fullthread cylinder head		66
1/2" RAPID® T-Lift		68

References

Idaho Central Credit Union Arena	70
Lookout tower on the Pyramidenkogel	71
Fyrtornet	72
World of Volvo	73

Safety & sustainability

RAPID® Secure: screw-in tool	74
Responsibility for the future	75



RAPID® screws

Application of self-tapping and self-drilling RAPID® screws

RAPID® wood drilling screws are self-drilling and self-tapping screws, which can be used to connect or reinforce structural wood elements and wood product elements, as well as connecting these structural elements with steel assemblies.

RAPID® screws are applied according to installation instructions, arrangement conditions and design provision according to NDS and ICC Evaluation Report ESR-4549. The latter provides design information spe-

cifically for applications involving self-tapping screws in softwood species such as Spruce, Pine, Fir, and Douglas Fir. This information is tailored explicitly for construction with self-tapping screws. Further informative recommendations how to apply RAPID® screws including several design notes are provided in ICC-ESR-4549, as well as the European Technical Assessment document ETA-12/0373. Make sure to review the latest version published.

Application instructions

RAPID® screws can be driven into wood and wood based products without pre-drilling or in pre-drilled holes with a diameter not exceeding the inner thread diameter D_r , given in ICC-ESR-4549.

For long self-tapping RAPID® screws or screws close to edge or end-grain a positioning hole of approximately five times the diameter ($5D$) may lead to greater precisions. Positioning holes do not count as predrilled. Ensuring equal loading of all screws in a connection is essential. In general, for all connections—and particularly for steel-to-timber connections—uniform screw insertion is required. A torque controlled application may be necessary. Thereby, the insertion moment must be less than the characteristic torsional strength of the screws, for corresponding values see ETA-12/0373.

Usually, in timber constructions insertion moments of 70 % to 80 % of the characteristic torsional strength are applied. The following table shows the torque settings that can be applied to the screwdriver for each screw size. These values are provided as guidelines and recommendations.

D_{nom}	approximate torque
1/4" (6 mm)	6 ft-lbs
5/16" (8 mm)	15 ft-lbs
3/8" (10 mm)	30 ft-lbs
1/2" (12 mm)	37 ft-lbs

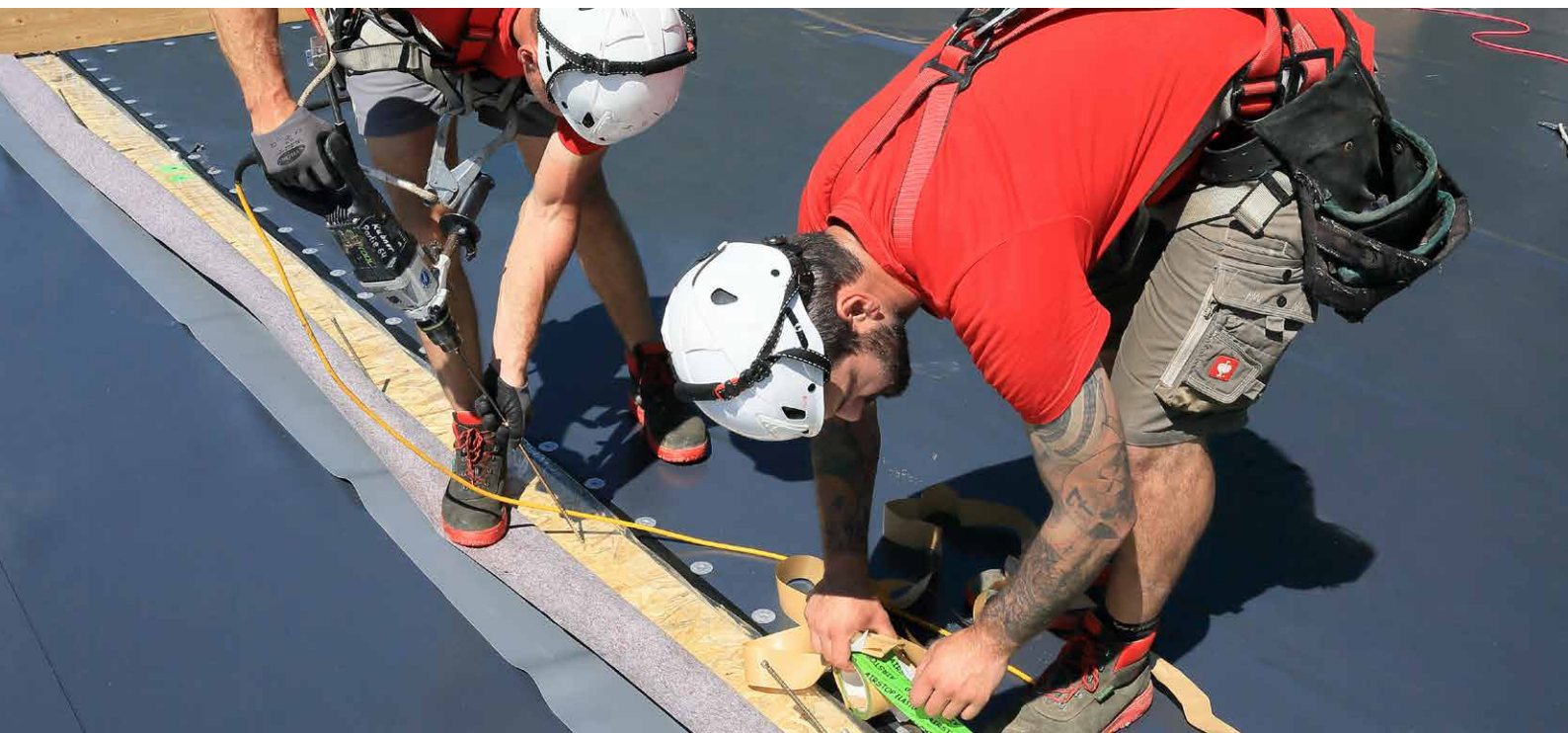

Partial thread vs fullthread

RAPID® partial thread

Partially threaded screws enable a stable connection of two components. The thread must be completely in the lower component (2). Partially threaded screws pull the upper component (1) onto the lower component (2) during the screwing-in process. In case of axial loading the head pull-through and thread pull-out (withdrawal) shall be considered.

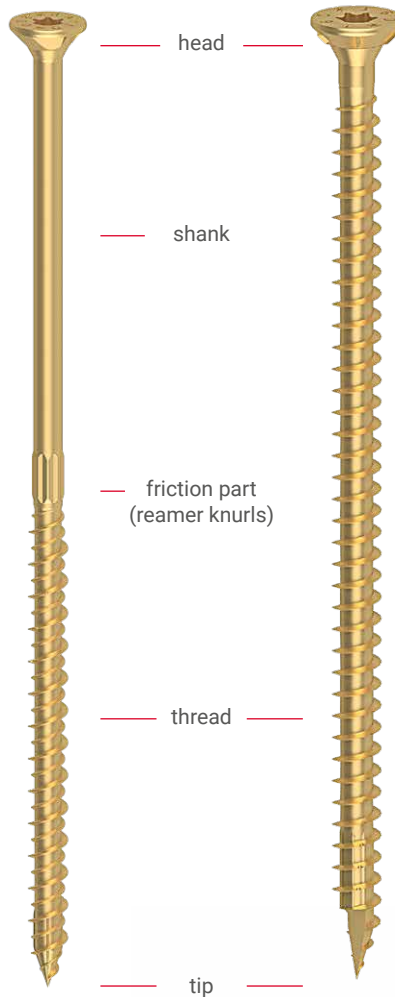
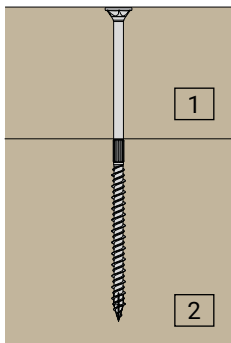

RAPID® fullthread

Fully threaded screws are used for versatile connection types. In structural steel-to-wood or wood-to-wood connections the screws are applied perpendicular to the surface or inclined, designated as active fasteners. To reinforce timber element capacity the screws are applied as passive fastener to increase tension or compression perpendicular to grain resistance at transverse connections, openings and more.

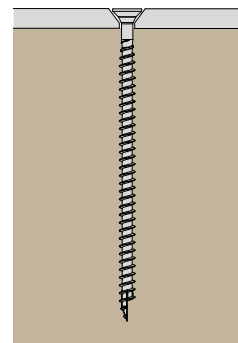

T-drive

The T-drive is screwed on with standard T-bits (or TX bits). The T-drive is the standard commercial designation for a hexalobular internal driving feature. Thanks to the six-star profile, it can distribute high torques evenly over the six sides of the drive and transmit them without additional contact pressure. Further advantages of the T-drive compared to the cross recess, for example, are:

- > longer service life (this applies to both the bit and the drive in the screw)
- > more precise screwing possible (even at low speeds)
- > lower probability of slipping
- > Automatic screwdriving systems can be used.



RAPID[®] screws

Head style

90° countersunk head with milling pockets



- > Milling pockets reduce tearing and splitting in the wood.
- > Sinks the head mills completely into the wood
- > Fits well in steel chamfers holes, without damaging the surface.

90° countersunk head with milling ribs



- > The ribs ensure optimum countersinking in the wood.
- > Reduce tearing and splitting in the wood.
- > Can be used in steel chamfers holes.

Washer head



- > Highest permissible head pull-through values allow high force transmission and ensure stable and strong connections.
- > No additional washers required, therefore faster and cheaper processing.

SuperSenkFix head



- > Innovative combination of countersunk head and washer head.
- > Clean and flush countersinking in connections with high head pull-through values – optimal for visible screwed connections.
- > Fits perfect in steel holes thanks to the shoulder under head.

Dual head



- > The external hexagon enables high force transmission during screw fastening, even with an impact driver (avoid hard screwdriving).
- > Using the T-drive saves time when screwing different screws.
- > Fits perfect in steel holes thanks to the shoulder under head.

Cylinder head



- > The small head allows very deep countersinking in wood (use long bits) - good for visible connections.
- > Minimize splitting effect of the wood.
- > Not suitable for metal-to-wood connections.



Photo © Timberframing, Frans Masereel Centrum

Special features

Friction part (compressing)



- > The straight friction part compacts the wood so that the smooth shank is exposed and does not rub.
- > Reduction of the screw-in torque, saves energy and time.

Cutting groove

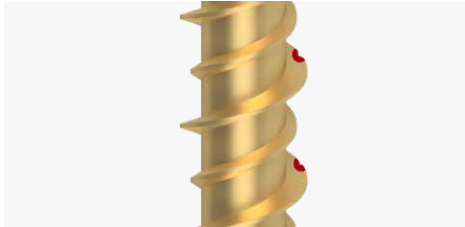

- > All thread types are equipped with a cutting groove.
- > It cuts the wood fibers and thus reduces the screw-in torque.

Thread

HiLo thread

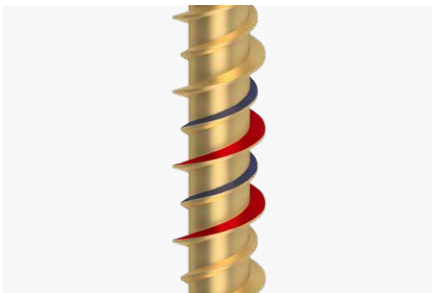

- > Is a double thread in which one flank is lower.
- > The high thread pitch enables very fast screwing in, saves time - compared to conventional wood construction screws.
- > The high structural properties guarantee a secure hold, even for oblique and cross grained wood screw connections.

Single thread

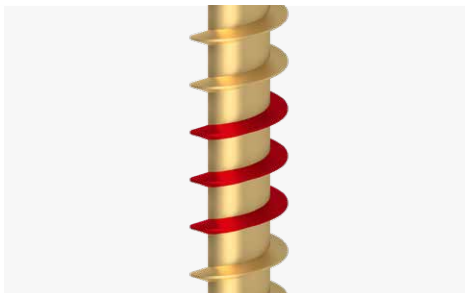

- > Provides constant low screw-in torques.
- > Excellent withdrawal values and high tensile strength.
- > These highest structural properties even under compressive stress, are ideal for reinforcements.

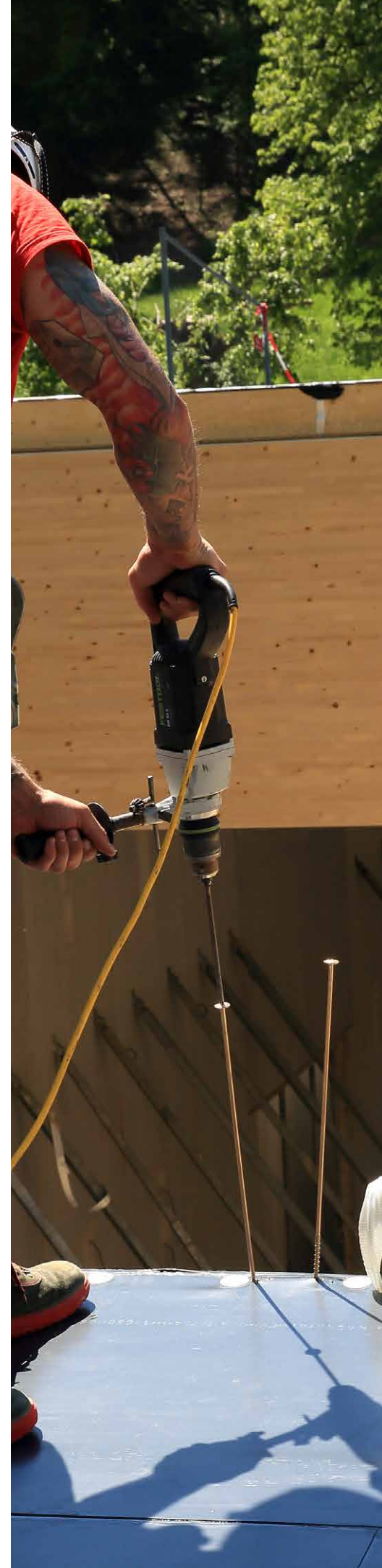

RAPID® screws

Tips

All tip types for RAPID® screws are patented and all these tips are also self-drilling and self-tapping. This means that the wood does not have to be pre-drilled, but it may be pre-drilled.

Exceptions are species with a high risk of splitting, such as Cedar, where we recommend pre-drilling.

The different tips were developed to reduce the biting time and the screwing torque as well as to minimize the splitting effect.

They have much less splitting and lower screw-in resistance compared to conventional wood construction screws.

Extra advantage with the half tip: no warping in the wood, the screw remains in the desired screw line.

Tip with ridged core and HiLo thread
(compressor option 1)

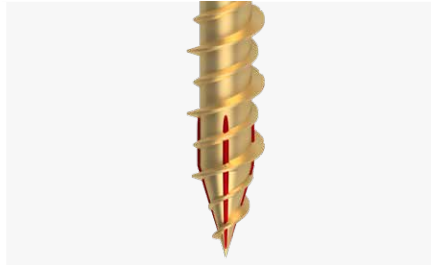

Tip with ridged core and single thread
(compressor option 1)

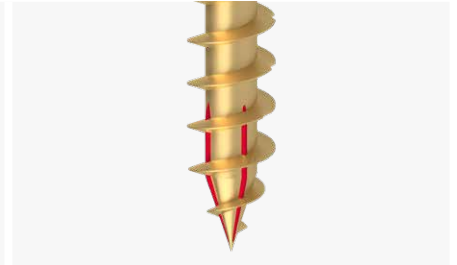

Full tip with compressor and single thread
(compressor option 2)

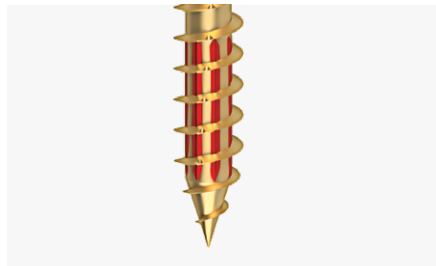

Half tip with compressor and single thread
(compressor option 2)

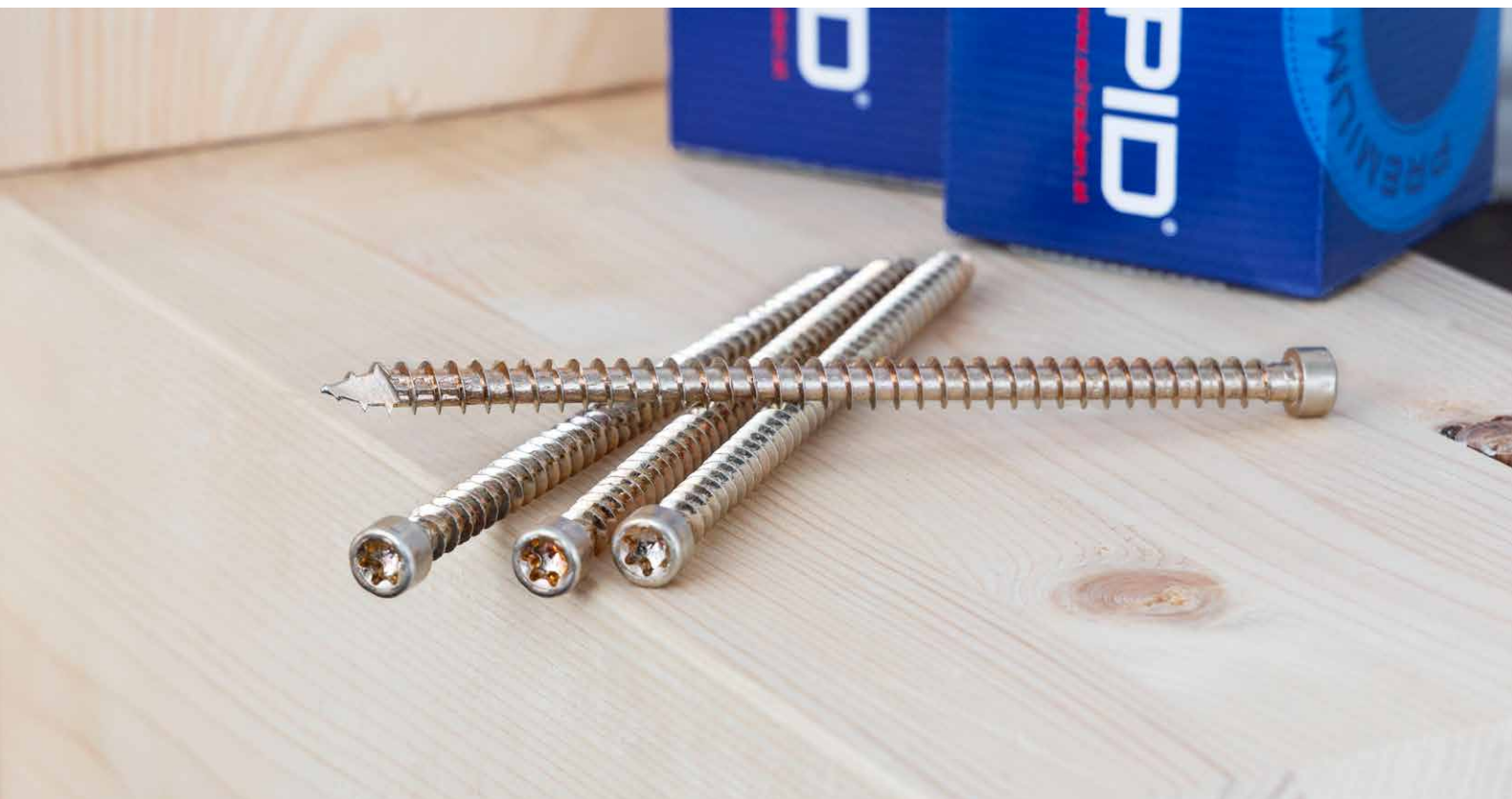
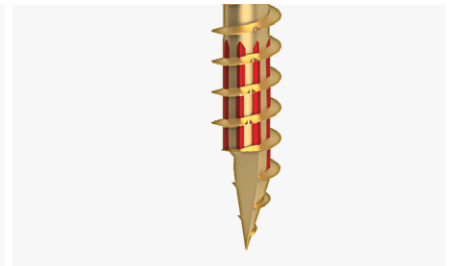

Applications RAPID® partial thread

DOUBLING RAFTERS (1)

The doubling to reinforce the rafter is usually carried out on the top or side of the rafter. RAPID® countersunk head is used here, which can be effortlessly recessed.

RAFTERS (2)

Partial thread screws, eg. RAPID® washer head, transfer the wind suction load and shear forces to the substructure through the screw heads.

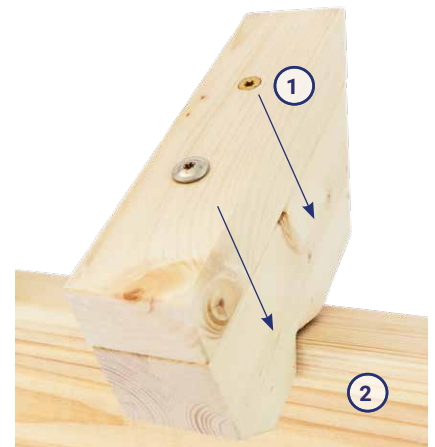

METAL PLATES AND SHAPED SHEET METAL PARTS

RAPID® Dual - and RAPID® SuperSenkFix screws are optimal for metal plates and shaped sheet metal parts.

These screws have an underhead shoulder which allows them to be optimally centred and to fit perfectly in the metal.

CLT WALLS AND FLOORS

RAPID® screws are approved according to ETA-12/0373 for application generally in side and end grain (0° and 90°), as well as for in side face and narrow edge of Cross-Laminated-Timber (CLT). Therefore RAPID® screws, especially the RAPID® SuperSenkFix, are ideal to connect wall and floor CLT panels.

Corner and wall screw connections are pulled tightly together and securely screwed with RAPID® SuperSenkFix.

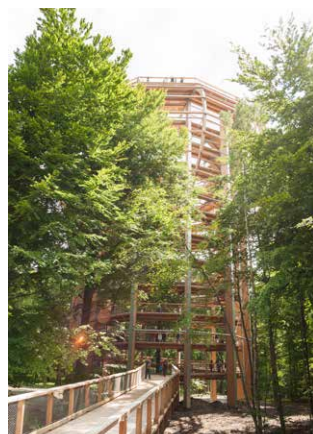

Photos © Baumturm Ruegen, Die Erlebnis Akademie AG

Applications RAPID® fullthread

BEARING REINFORCEMENT WITH STEEL PLATE AND FULLTHREAD SCREWS (1)

RAPID® fullthread screws transfer the support load from the timber section directly to the steel plate through the screw heads. They distribute the force evenly into the end grain of the support.

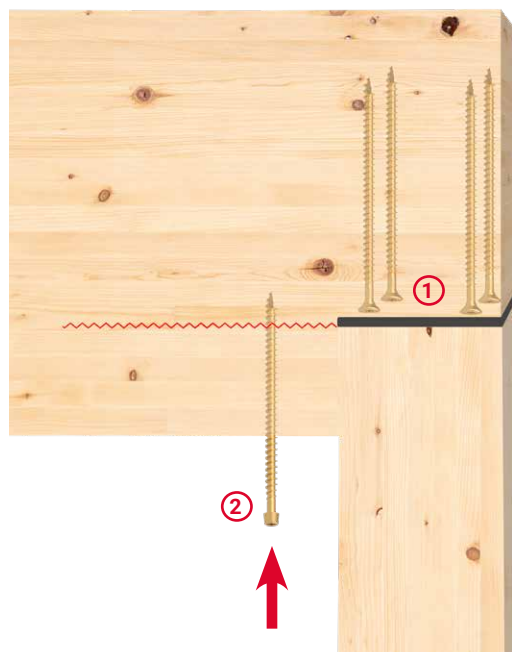

TRANSVERSE TENSILE REINFORCEMENT FOR NOTCHING (2)

The structural engineer must review the requirement. If the transverse tensile load is too high for the timber section, RAPID® fullthread screws will be used to reinforce and secure the beam to prevent splitting along the red line area.

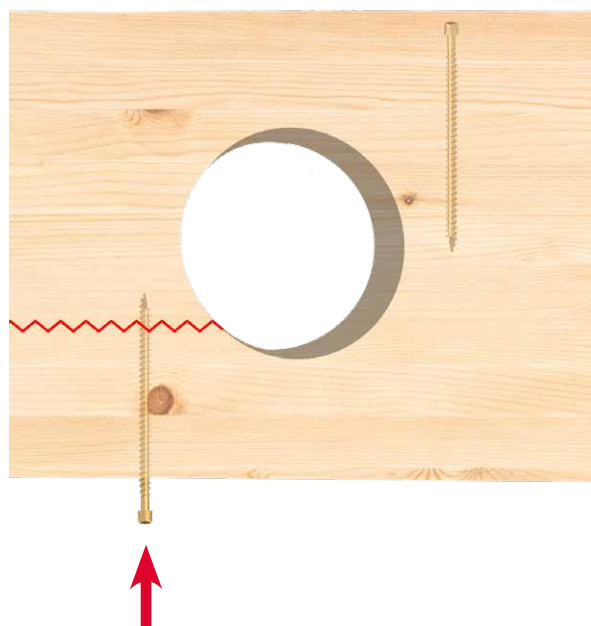

REINFORCEMENT OF OPENINGS WITH LONG FULL-THREAD SCREWS

The area marked in red indicates the risk of cracking. Aiming the same thread length above and below this mark increases the beam resistance. The advantage of RAPID® fullthread screws with cylinder head is, that with using a long bit the screw heads can be sunken for an optimal positioning.

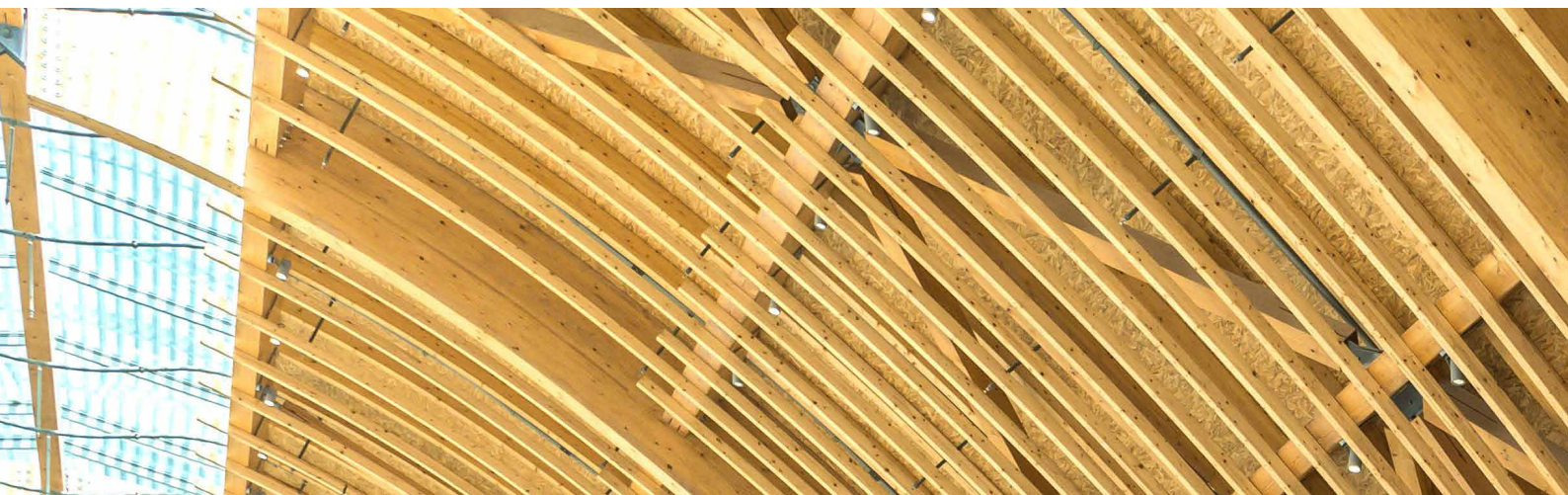

CROSS LAMINATED TIMBER (IN PLANE JOINT)
RAPID® fullthread cylinderhead are used to create a shear-resistant screwing pattern for cross laminated timber panels.

TIP: the connection should first be pulled tightly together using e.g., partial thread screws or a beam puller.
The pitch of the screws should be oriented in the direction of the main load.

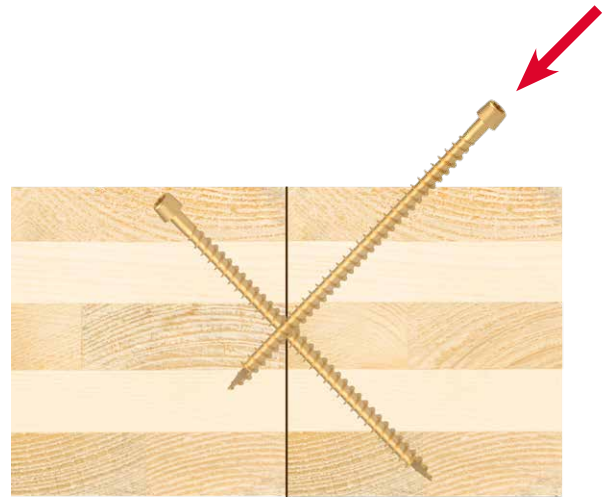

CONNECTIONS AT THE BASE POINT OF THE SUPPORT

RAPID® fullthread screws with a countersunk head are best suited for this application. Shear forces and wind suction are effectively transferred. The RAPID® screws offers a high degree of security with 500 hours of corrosion resistance, more available under request.

Info: In areas exposed to weather (wet service condition > 19%), stainless steel screws should be used in accordance with the timber structure design code. It is the designer responsibility to investigate the extent of the corrosion protection requirements.

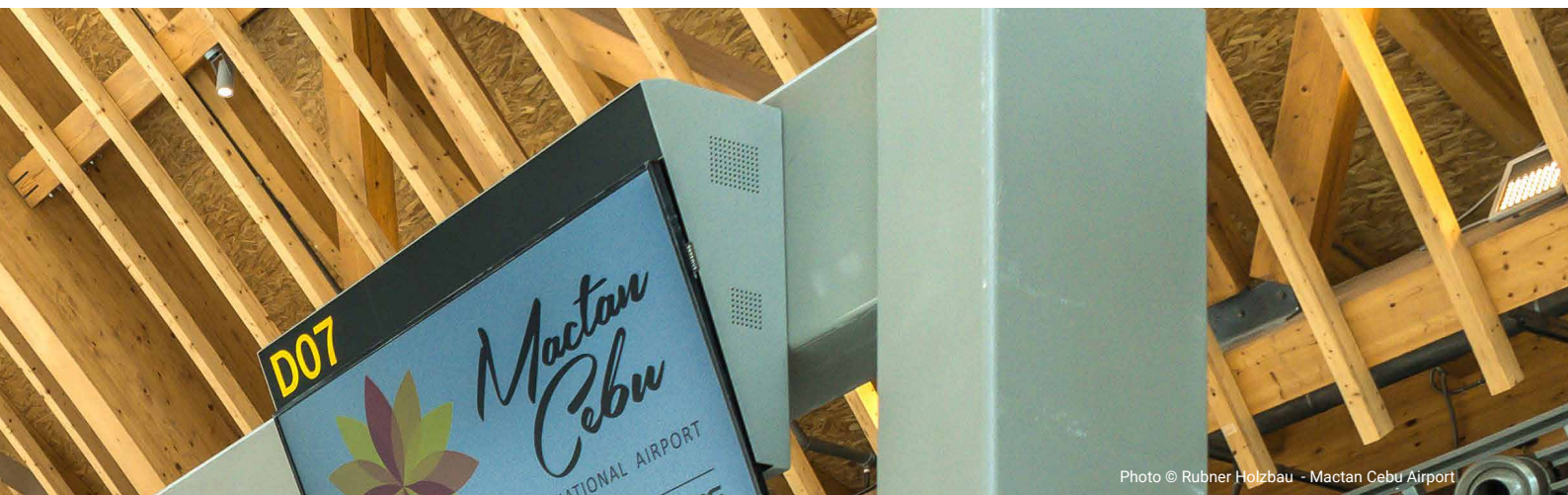

Photo © Rubner Holzbau - Mactan Cebu Airport

Comparable terms

between NDS, ICC-ESR-4549 and ETA-12/0373:2022

Listed variables are similar, do not assume they are equal. Consider the given definitions, respectively, which are reproduced from the standard and approvals as accurately as possible.

ICC-ES ESR 4549:2024 NDS:2024 (semi probabilistic and empiric design)		ETA-12/0373:2022 (ETA = European Technical Approval)	
SCREW DIMENSIONS			
D_{nom} ...	outside thread diameter, [in (mm)]	d ...	outer thread diameter, [mm], alternative term Φ
D_{nom} ...	screw size designation, [in (mm)]	Dim ...	screw diameter, screw size, [mm]
D_H ...	diameter of screw head or integral washer, [in (mm)]	d_k ...	head diameter, [mm]
D_s ...	unthreaded shank diameter, [in (mm)]	d_s ...	shank diameter, [mm]
D_r ...	minor thread (root) diameter, [in (mm)]	d_i ...	inner thread diameter, [mm]
L ...	overall screw length, [in (mm)]	L ...	screw length, [mm]
L_{thread} ...	length of thread, [in (mm)]	b ...	thread length (including the tip length), [mm]
L_{tip} ...	length of tip, [in (mm)]	l_p ...	length of drilling tip, [mm]
		l_{sp} ...	length of tip, [mm]
ARRANGEMENT PARAMETERS			
L_{eff} ...	effective embedded thread length, [in (mm)]	l_{ef} ...	threaded part in the timber member, including the tip at point side member, [mm]
$L_{eff,m}$...	effective embedded thread length in the wood main member, [in (mm)]		
$L_{eff,s}$...	effective embedded thread length in the wood side member, [in (mm)]		
L_{un} ...	length of unthreaded portion of the fastener, measured from the head of the fastener to the start of the thread, [in (mm)]		
α ...	angle between the axis of the screw and the grain of the applicable wood member, [°] ICC-ESR-4549 Note: NDS:2024 define α as the angle between the wood surface and the direction of applied load in connections with combined lateral and withdrawal loads, [°]	α ...	angle between fastener axis and grain direction of the timber member, [°]
β ...	angle between the fastener axis and the shear plane of a connections, [°]		
θ ...	maximum angle between the direction of load and the direction of the grain of the wood member, [°]	γ ...	angle between the applied load and the grain direction of the timber member, [°]
a_1 ...	spacing between fasteners, parallel to grain, for loading parallel or perpendicular to grain, axial loading or inclined fasteners	a_1 ...	spacing between fasteners parallel to grain
a_2 ...	spacing between fasteners, perpendicular to grain, for loading parallel or perpendicular to grain, axial loading or inclined fasteners	a_2 ...	spacing between fasteners perpendicular to grain
$a_{end,CG}$...	end distance for inclined fasteners from the centre of gravity	$a_{1,CG}$...	end distance of the centre of gravity of the threaded part in the timber member for axially loaded screws
$a_{edge,CG}$...	edge distance for inclined fasteners from the centre of gravity	$a_{2,CG}$...	edge distance of the centre of gravity of the threaded part in the timber member for axially loaded screws
$a_{end,2}$...	end distance for loading perpendicular to grain or away from end	$a_{3,c}$...	unloaded end distance for laterally loaded screws
$a_{end,2}$...	end distance for axial loading		
$a_{end,1}$...	end distance for loading toward end	$a_{3,t}$...	loaded end distance for laterally loaded screws
$a_{edge,2}$...	edge distance for loading parallel to grain or away from edge	$a_{4,c}$...	unloaded edge distance for laterally loaded screws
$a_{edge,2}$...	edge distance for axial loading		
$a_{edge,1}$...	edge distance for loading toward edge	$a_{4,t}$...	loaded edge distance for laterally loaded screws
$a_{2,cross}$...	spacing between fasteners, perpendicular to grain, for inclined and crossed screws	a_{cross} ...	spacing between crossing screws for a crossed screw couple perpendicular to a plane parallel to the grain

ICC-ES ESR 4549:2024 NDS:2024 (semi probabilistic and empiric design)		ETA-12/0373:2022 (ETA = European Technical Approval)	
RESISTANCE PARAMETERS			
W ...	reference unit withdrawal design value, RAPID® screws add the index "90" to underline, that W_{90} is the reference withdrawal design values for installation perpendicular to the face of the wood member (perpendicular to grain direction) [lbf/in]	$f_{ax,90,k}$... $f_{ax,90,d}$...	characteristic withdrawal parameter, [N/mm ²] design withdrawal parameter, [N/mm ²]
W' ...	corresponding adjusted withdrawal design value, [lbf/in]		
W_H ... W'_H ...	reference head pull-through design value, [lbf (N)] corresponding adjusted head pull-through design value, [lbf (N)]	$f_{head,k}$... $f_{head,d}$...	characteristic head pull-through parameter, [N/mm ²] design head pull-through parameter, [N/mm ²]
$L_{emb,w}$...	minimum required embedded thread length in holding member, including tip, applicable to tabulated withdrawal design value W , [in (mm)]		minimum penetration length of screws in the load-bearing wood-based member, independent of intended loading direction, <i>any term used</i>
Z ... Z' ... $Z_{ }$... Z_{\perp} ...	reference lateral design value for single shear (two-member) or double shear (three member) wood-to-wood or steel-to-wood connections, [lbf (N)] corresponding adjusted design value, [lbf (N)] reference lateral design value for fasteners loaded parallel to the wood grain, [lbf (N)] reference lateral design value for fasteners loaded perpendicular to the wood grain, [lbf (N)]	$F_{v,k}$... $F_{v,d}$...	characteristic lateral resistance of a screw, [N] corresponding design resistance, [N]
$L_{emb,l}$...	minimum required embedded thread length in holding member, including tip, applicable to tabulated lateral design value Z , [in (mm)]		minimum penetration length of screws in the load-bearing wood-based member, independent of intended loading direction, <i>any term used</i>
$t_{s,w}$...	thickness of wood side member, [in (mm)]	t ...	member thickness, [mm]
$t_{s,s}$...	thickness of steel side member, [in (mm)]	t ...	member thickness, [mm]
N_a ... N_u ...	allowable tension strength of the fastener according to ICC-ESR 4549 for use in ASD, [lbf (N)]; corresponding to R_n/Ω of AISC design tension strength of the fastener according to ICC-ESR 4549 for use in LFRD, [lbf (N)]; corresponding to ΦR_n of AISC	$f_{tens,k}$... $f_{tens,d}$...	characteristic tensile strength, [kN] design tensile strength, [kN]
V_a ... V_u ... V' ...	allowable shear strength of the fastener for use in ASD, [lbf (N)] design shear strength of the fastener for use in LFRD, [lbf (N)] corresponding adjusted tension strength, [lbf (N)]		not specified in Europe for high performing screws
$F_{yb,spec}$...	minimum specified bending yield strength, [psi]	f_{yk} ...	characteristic yield strength, [N/mm ²]
C_g ...	group action factor for laterally loaded fasteners (NDS)	n_{ef} ... n_{ef} ...	effective number of screws in a row parallel to grain for laterally loaded screws effective number of screws in a group for axially loaded screws
RELEVANT WOOD MEMBER PARAMETERS			
SG_{NDS} ... SG_{eg} ...	assigned specific gravity for the applicable species combination, [dimensionless] equivalent specific gravity for structural composite lumber, as reported by ICC-ES Evaluation Report, [dimensionless]	ρ_k ... ρ_{mean} ...	characteristic density of the wooden member, [kg/m ³] mean density of the wooden member, [kg/m ³]

UNIT CONVERSION FACTORS:

1 psi \equiv 0.00689 N/mm²

1 psi \equiv 6.89 kPa

1 MPa \equiv 1 N/mm² \equiv 10 bar

1 N/mm² \equiv 145.038 psi

1 in \equiv 25.4 mm

1 lbf \equiv 4.448 N

1 N \equiv 0.225 lbf

1 ft-lbs \equiv 1.3558 Nm

Instruction notes to designers and professionals

- 01) Provided design and application information in this document are based on the National Design Specification® for Wood Construction NDS 2018 Edition 2024 and the ICC-ES Evaluation Report ESR-4549 issued June 2024, as well as more detailed application conditions outlined in ETA-12/0373:2022-03-30 (see also disclaimer).
- 02) General connections and details in this US-Design-Guide may differ from project specific inside conditions and requirements and cannot be assumed to be valid for all of them.
- 03) The herein suggestions, shown details, listed values and application conditions for a screw, a crossed screws pair or for a screw group are based on the bearing capacity of the fasteners. Additionally, the capacity of wood element and possibly further steel components must be verified with reference to the corresponding standards, respectively. This includes among other things the capacity against all possible brittle wood failure modes in the area of the connection and of the wood element itself, as e.g. shear, rolling shear, net tension and any kind of plug or block shear failure and splitting failure due to a loading perpendicular-to-grain.
- 04) To determine the adjusted values Z' , W' and W'_H for Allowable Stress Design (ASD) or for Load and Resistance Factor Design (LRFD) all reference lateral design values Z , as well as all design values based on withdrawal W , head pull-through W_H and screw tension strength N have to be multiplied by all applicable adjustment factors in accordance with the NDS, corresponding to ASD or LRFD respectively. In case of the screw tension strength limits the design, values N must be adjusted in accordance with AISC 360.
- 05) RAPID® screws are intended to be used only in untreated wood applications and are intended to be applied as well as used throughout the service life in dry service conditions ($\leq 19\%$) and temperature $T \leq 100^\circ\text{F}$, consequently, $C_M = 1.0$ and $C_T = 1.0$
- 06) According to ICC-ES Evaluation Report for lateral design the minimum embedded length in the wood main member is $6D$. The dowel bearing strength must be determined with screw length excluding the tip length l_{tip} . Additional reference lateral design values are provided in ICC-ESR-4549.
- 07) Generally, the required minimum embedded length for reference withdrawal design value is $6D$ including the tip. The required minimum embedded length of screws in end grain according to ETA-12/0373:2022 and an angle between the screw axis and the grain of $< 15^\circ$ is $20D$ but not covered by ICC-ESR-4549. Even partial thread screws can fulfil this required embedded length in end grain.
- 08) Generally, at least two RAPID® screws must be used in a connection. For connections in end grain and an angle between the screw axis and the grain of $< 15^\circ$ according to ETA-12/0373:2022 at least 4 screws must be used, not covered by ICC-ESR-4549.
- 09) If RAPID® screws are used as reinforcement against perpendicular to grain splitting or longitudinal to grain shear failure even solely one screw or as many as required, respectively, can be applied. Highly probable crack position with anchorage on both sides including the required design provision must be considered for any kind of application.
- 10) Considering the spacing and distance requirements RAPID® screws can be applied even in the plane surface of Cross Laminated Timber (CLT). For screws applied in the narrow edge of CLT according to ETA-12/0373:2022, it is recommended to use requirements on basis of this not covered by ICC-ESR-4549.
- 11) In shear connections with screws inclined in one direction only, $30^\circ \leq \alpha \leq 60^\circ$, and where the screws are loaded (mainly) axial and only in tension, the members are pressed together due to the load equilibrium and friction occurs. An example of such a connection is shown on page 20. According to ETA-12/0373:2022 friction can be considered for steel-to-wood and wood-to-wood connections by a friction coefficient of $\mu = 0.30$. These applications are not covered by ICC-ESR-4549: It is on the responsibility of the qualified designer to apply inclined screws in shear connections, to consider friction loads and to justify the connection geometry to the satisfaction of the code official.
- 12) Different screw strength, withdrawal and head pull-through capacities depending on the screw type must be taken into account in design for every application.
- 13) Structural outer steel elements must have a tensile strength of $F_u \geq 52$ ksi and be designed in accordance with requirements of ICC-ESR-4549 and applicable US steel standards. The minimum design thickness (base-metal thickness exclusive of any coating) is 0.236 inch (6 mm).
- 14) RAPID® screws shall be subjected according to ETA-12/0373:2022 to static and quasi static actions only. Ductility requirements may fulfill the entire connection including outer steel plates and assemblies.

Adjusted design values

ADJUSTED LATERAL DESIGN VALUE Z'

$$Z' = Z \cdot C'$$

Z ... reference lateral design value provided in design tables of ICC-ESR-4549 or calculated acc. to NDS. To determine dowel bearing strength values with Table 12.3.3 of NDS the minimum of the shank diameter D_s or root diameter D_r has to be taken into account.

C' ... adjustment factor for the connection, considering $C_M, C_t, C_{\Delta}, C_{eg}, C_{df}, C_{tr}, C_g$ and

- C_D for ASD design
- $K_F \cdot \Phi \cdot \lambda = 3.32 \cdot 0.65 \cdot \lambda$ for LRFD design
- Note: at designers discretion, in case of loading parallel to grain ($\theta = 0^\circ$) and a screw axis to grain angle of $\alpha = 90^\circ$, for all screw diameters C_g may be substituted by n_{eff} according to the provisions below

n_{eff} ... effective total number of screws

$$n_{eff} = n_{\parallel}^{kef} \cdot n_{row}$$

n_{\parallel} ... number of screws in a row parallel-to-grain

n_{row} ... number of rows

k_{ef} as following:

a_t	requirement in acc. with ICC-ESR 4549	k_{ef}
5D	pre-drilled only for $D_s \geq 1/4"$	0.50
7D		0.70
10D	pre-drilled	0.85
14D	pre-drilled	1.00
$\geq 15D$		1.00

for fully threaded screws $D_s = D_r$

Where inclined screws are applied in responsibility as indicated in point 11) of the construction notes, resulting in mainly axially loading, head pull-through, withdrawal or tension strength design value should be used, respectively.

ADJUSTED HEAD PULL-THROUGH DESIGN VALUE W'_H

$$W'_H = W_H \cdot C' \cdot n_{eff}$$

W_H ... reference head pull through design value for installation perpendicular to the face of the wood member (perpendicular to grain direction), provided in design tables of ICC-ESR-4549, [lbf], (see also disclaimer)

C' ... adjustment factors for the connection, considering C_M, C_t , and

- C_D for ASD design
- $K_F \cdot \Phi \cdot \lambda = 3.32 \cdot 0.65 \cdot \lambda$ for LRFD design

n ... number of screws in the connection

n_{eff} ... Schmid Schrauben Hainfeld recommend to consider a group effect at determining the head pull-through resistance by substitution of the total number of screws n with an effective number of screws n_{eff}

- $n_{eff} = n^{0.9}$ generally, for connections with axially loaded screws
- $n_{eff} = \max\{n^{0.9}, 0.9 \cdot n\}$ for shear connections with mainly axially loaded and equally tightened screws (torque controlled)

ADJUSTED WITHDRAWAL DESIGN VALUE W'

$$W' = W_{90} \cdot R_a \cdot C' \cdot l_{eff} \cdot n_{eff}$$

W_{90} ... reference withdrawal design values for installation perpendicular to the face of the wood member (perpendicular to grain direction), provided in design tables of ICC-ESR-4549 as W , [lbf/in], (also page 15 and disclaimer)

R_a ... reduction factor to consider load grain angles $30^\circ \leq \alpha \leq 90^\circ$, when applying screws from side face, according to ICC-ESR-4549

C' ... adjustment factors for the connection, considering C_M, C_t and

- C_D for ASD design
- $K_F \cdot \Phi \cdot \lambda = 3.32 \cdot 0.65 \cdot \lambda$ for LRFD design
- C_{eg} for ASD as well as LRFD design

If the qualified designer refer on its own responsibility on ETA-12/0373:2022 screws can be applied in end grain with screw axis parallel to grain, $\alpha = 0^\circ$ possible in sawn timber, structural timber and in the narrow edge of CLT. In this case Schmid Schrauben Hainfeld recommend to set $C_{eg} = 0.3$ and corresponding linear interpolation up to the reduction factor R_a for 30° .

l_{eff} ... effective embedded thread length in the wood, according to ICC-ESR-4549 including the tip, [in]

n ... number of screws in the connection

n_{eff} ... Schmid Schrauben Hainfeld recommend to consider a group effect at determining the withdrawal resistance by substitution of the total number of screws n with an effective number of screws n_{eff}

- $n_{eff} = n^{0.9}$ generally, for connections with axially loaded screws
- $n_{eff} = \max\{n^{0.9}, 0.9 \cdot n\}$ for shear connections with mainly axially loaded and equally tightened (torque controlled) screws and $30^\circ \leq \alpha \leq 60^\circ$
- $n_{eff} = n$ for screws used as reinforcement

TENSION STEEL STRENGTH OF THE RAPID® SCREWS N

Allowable and design tension strength are listed for each RAPID® screws in this US Design Guide corresponding to ICC-ESR-4549.

Consider that RAPID® fullthread and RAPID® partial thread screws have different strength capacities:

- > tensile strength (N_a used for ASD and N_u for LRFD design, respectively)
- > bending yield strength F_{yb}

COMBINED LATERAL AND AXIAL LOADING

In case of combined lateral and axial loading of the screws, the adjusted lateral design value must be determined as following. In case of wood to wood connected by partial threaded screws replace W' with $\min\{W'; W'_{\mu}\}$.

$$Z'_\alpha = \frac{W' \cdot Z'}{W' \cdot \cos^2 \alpha + Z' \cdot \sin^2 \alpha}$$

Minimum spacing and distance

Connection geometry requirements based on outside thread diameter D acc. to ICC-ESR-4549 installed into sawn lumber, structural glued laminated timber (GL) and into the face of cross laminated timber (CLT) panels ^{1, 2, 3, 4, 5}.

LATERALLY LOADED screws (installed into face side)		Minimum spacing or distance					
		D_{nom} of 1/4" and 5/16" (6 mm and 8 mm)			D_{nom} of 3/8" and 1/2" (10 mm and 12 mm)		
		self-drilled		Predrilled hole	self-drilled		Predrilled hole
SG_{NDS} < 0.50	SG_{NDS} ≥ 0.50	SG_{NDS} < 0.50	SG_{NDS} ≥ 0.50				
END DISTANCE							
Loading towards end	$a_{end,1}$	15D	20D	12D	15D	20D	7D
Loading perpendicular to grain or away from end	$a_{end,2}$	10D	15D	7D	10D	15D	4D
EDGE DISTANCE							
Loading towards edge	$a_{edge,1}$	10D	12D	7D	10D	12D	4D
Loading parallel to grain or away from edge	$a_{edge,2}$	5D	7D	3D	5D	7D	3D
SPACING BETWEEN FASTENERS, PARALLEL TO GRAIN							
Loading parallel to grain	a_1	15D	15D	10D	15D	15D	5D
Loading perpendicular to grain	a_1	10D	10D	5D	10D	10D	5D
SPACING BETWEEN FASTENERS, PERPENDICULAR TO GRAIN							
Lateral loading	a_2	5D	7D	4D	5D	7D	5D

AXIALLY LOADED and INCLINED screws (installed into face side)		Minimum spacing or distance					
		D_{nom} of 1/4" and 5/16" (6 mm and 8 mm)			D_{nom} of 3/8" and 1/2" (10 mm and 12 mm)		
		self-drilled		Predrilled hole	self-drilled		Predrilled hole
SG_{NDS} < 0.50	SG_{NDS} ≥ 0.50	SG_{NDS} < 0.50	SG_{NDS} ≥ 0.50				
END DISTANCE							
Axial loading	$a_{end,2}$	10D	10D	7D	10D	10D	4D
Inclined fasteners	$a_{end,CG}$						
EDGE DISTANCE							
Axial loading	$a_{edge,2}$	4D	4D	3D	4D	4D	3D
Inclined fasteners	$a_{edge,CG}$						
SPACING BETWEEN FASTENERS, PARALLEL TO GRAIN							
Axial loading and inclined fasteners	a_1	7D	7D	7D	7D	7D	5D
SPACING BETWEEN FASTENERS, PERPENDICULAR TO GRAIN							
Axial loading and inclined fasteners	a_2	4D	4D	3D	5D	5D	5D
Inclined fastener, crossed screws	$a_{2,cross}$	1.5D	1.5D	1.5D	1.5D	1.5D	1.5D

For SI: 1 inch = 25.4 mm.

¹⁾End distances, edge distances and fastener spacing must be sufficient to prevent splitting of the wood, or as required by this table, whichever is the more restrictive.

²⁾Wood member stresses must be checked in accordance with Section 11.1.2. and Appendix E of the NDS, and end distances, edge distances and fastener spacing may need to be increased accordingly.

³⁾Tabulated values are applicable for wood-to-wood and metal-to-wood connections.

⁴⁾For CLT products, parallel and perpendicular-to-grain descriptions apply to the grain orientation at the shear plane for lateral loading and to the face grain orientation for withdrawal loading.

⁵⁾For a more detailed information on predrilling, see ICC-ESR-4549.

SPACING, END AND EDGE DISTANCES DEFINITIONS FOR RAPID® SCREWS INSTALLED PERPENDICULAR TO GRAIN ACC. TO ICC-ESR 4549 (LATERALLY LOADING)

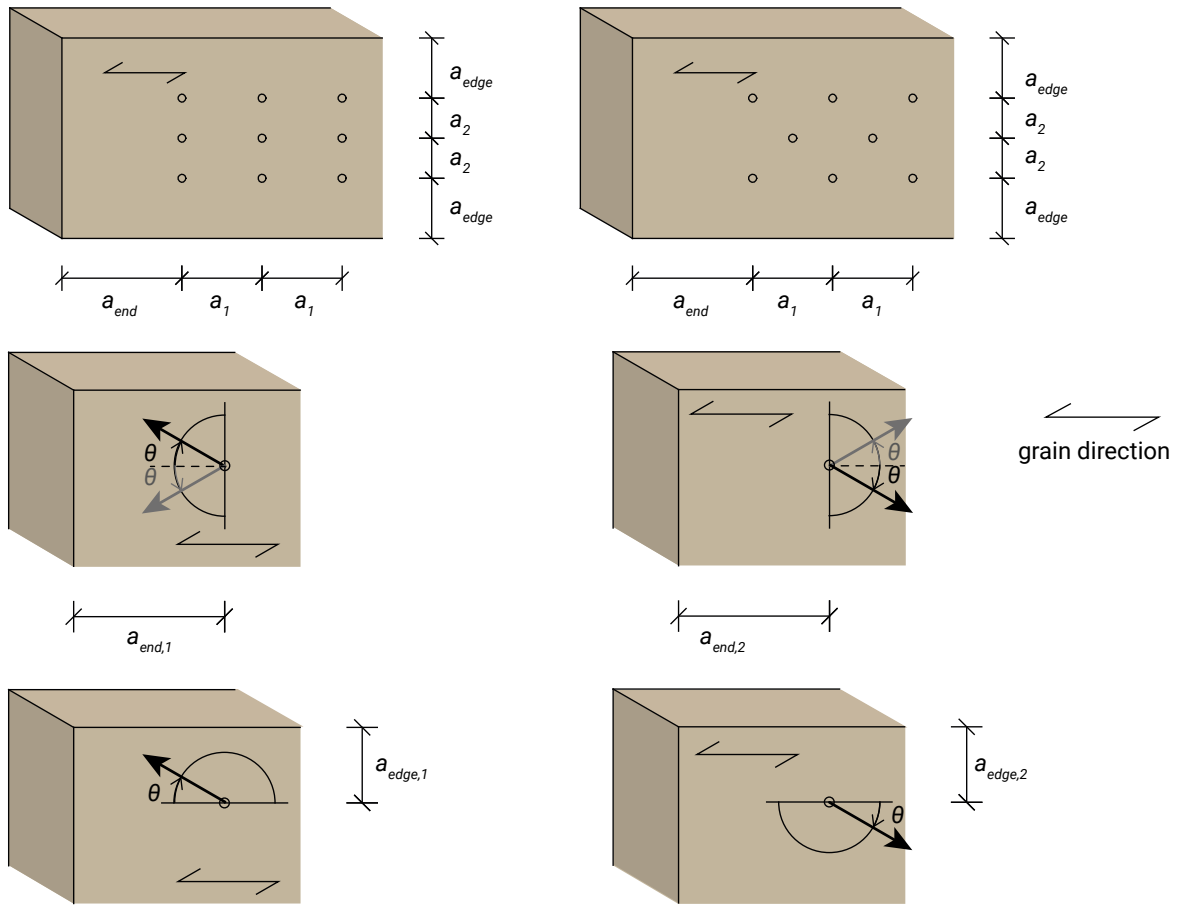

SPACING, END AND EDGE DISTANCES DEFINITIONS FOR RAPID® SCREWS FOR INCLINED AND CROSSED SCREWS LOADED MAINLY AXIALLY

It's on the responsibility of the qualified designer to apply inclines screws and to justify the connection geometry to the satisfaction of the code official.

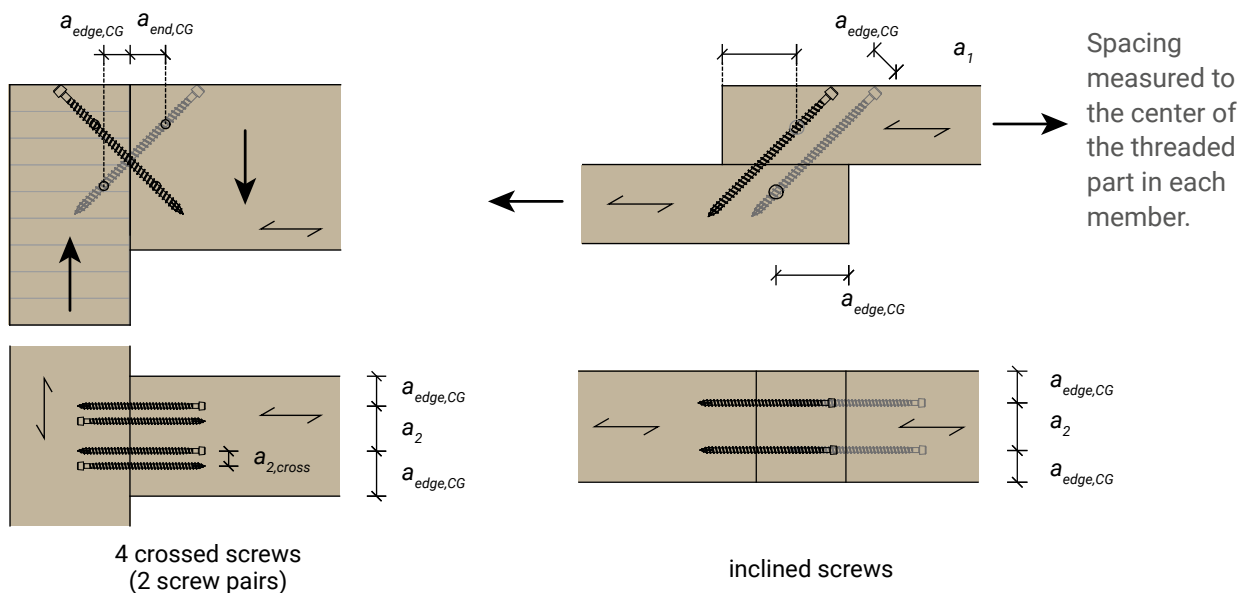

4 crossed screws (2 screw pairs): following distance $a_{end,CG} \geq 10D$ acc. to ICC-ESR-4549 result in screws length requirements of $42D$. Application with distance $a_{end,CG} \geq 5D$ acc. to ETA-12/0373 result in more practicable application with symmetrical but not covered by ICC-ESR-4549. The applied value for $a_{end,CG}$ is on the responsibility of the designer.

Further geometry requirements

APPLICATIONS WITH MAINLY AXIALLY LOADED SCREWS

Tension lap joint with screws inclined in one direction only (shear connection), where the screws are loaded (mainly) axial and only in tension. These applications are not covered by ICC-ESR-4549: It's on the responsibility of the qualified designer to apply inclines screws and to justify the connection geometry to the satisfaction of the code official.

Overlap screws in case of such a symmetric joint.

Spacing measured to the center of the threaded part in each member.

Tension perpendicular to grain reinforcement with one or more screws in a row perpendicular to grain. End distance according to ETA-12/0373 provides screw position and reinforcement closer to potential crack building zone.

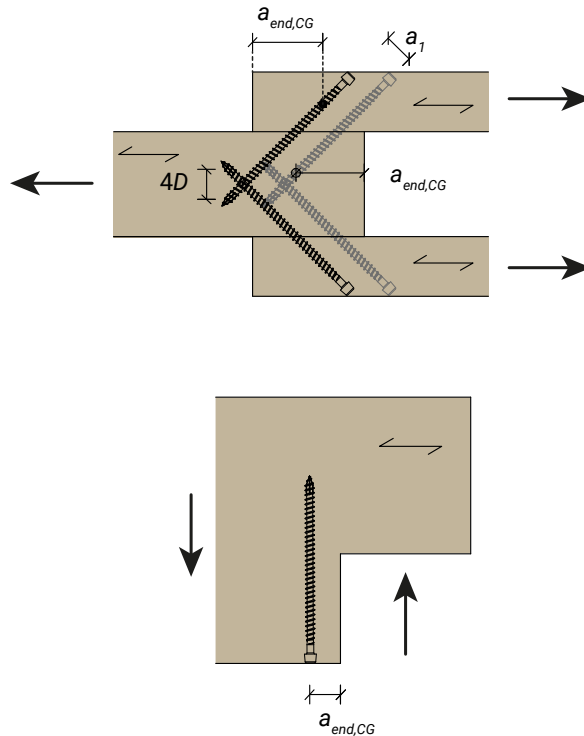

MINIMUM THICKNESS

of sawn lumber and structural glued laminated timber (GL) for softwood species S-P-F and for screws installed with or without predrilling acc. to ETA-12/0373

D_{nom}	1/4" (6 mm)	5/16" (8 mm)	3/8" (10 mm)	1/2" (12 mm)
LATERALLY LOADED screws	15/16" (24 mm)	1-3/16" (30 mm)	1-9/16" (40 mm)	3-3/16" (80 mm)
AXIALLY LOADED and INCLINED screws	12D			

- > Wood species at risk of splitting (e.g. Douglas Fir, Silver Fir) should be predrilled or use a higher minimum thickness, e.g. in accordance with product specifications.
- > If the timber does not meet the minimum thickness, it should be generally predrilled.
- > The minimum embedment length of the screws is generally $6D$ and separate requirements apply for end grain applications.

Spacing and distances, CLT

Spacing, end and edge distances definitions for RAPID® screws in the face of CLT acc. to ICC-ESR 4549 (shown for laterally loading).

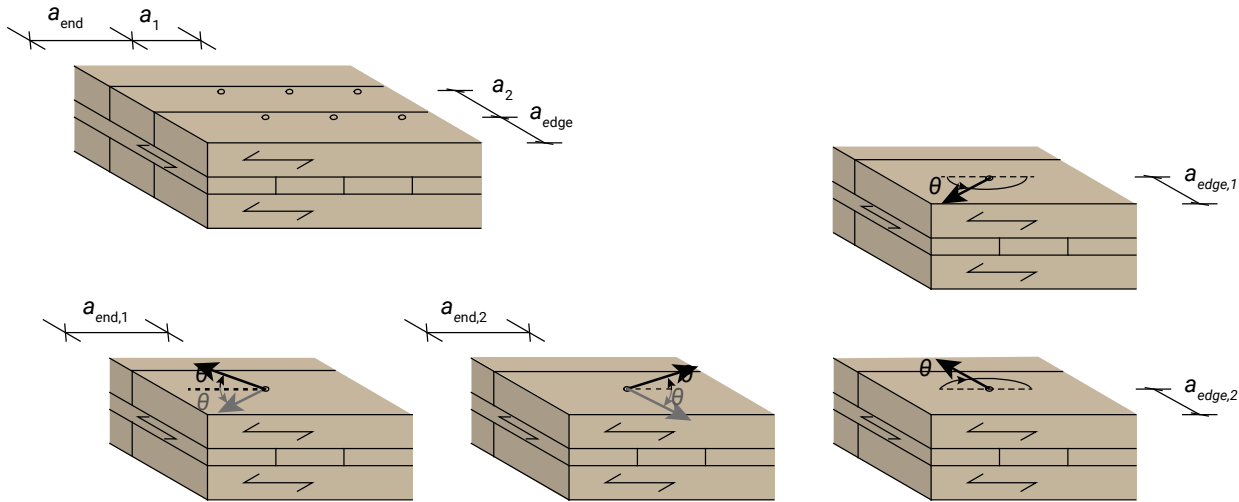

Self-tapping screws in the narrow edge of Cross Laminated Timber are outside the scope of the ICC-ESR-4549. It is on the responsibility of the designer to apply screws in the narrow edge of CLT. Following table provide spacing, end and edge distances for RAPID® screws in the narrow edge of CLT according to ETA-12/0373 (for laterally or axially loading) and according to NDS for fasteners as for example lag screws.

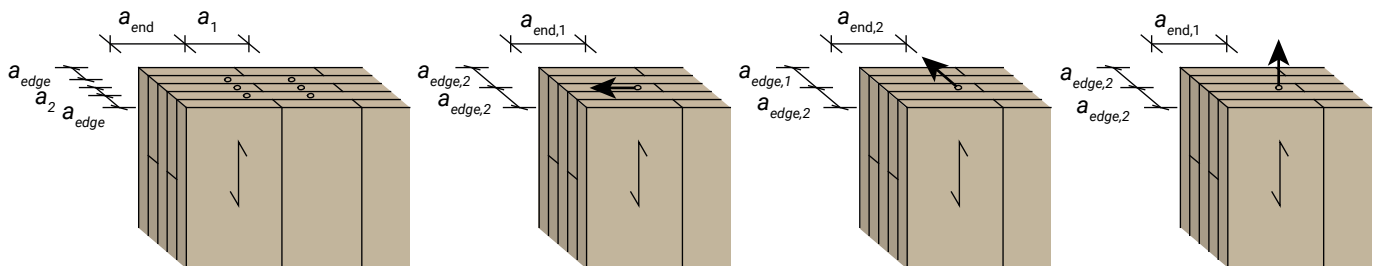

	END DISTANCE		EDGE DISTANCE		SPACING BETWEEN TWO FASTENERS	
	loading parallel to plain of CLT and toward end	loading perpendicular to plain of CLT or away from end	loading perpendicular to plain of CLT and toward edge	loading perpendicular to plain of CLT and away from edge	in a row parallel to plain of CLT	in a row perpendicular to plain of CLT
	$a_{end,1}$	$a_{end,2}$	$a_{edge,1}$	$a_{edge,2}$	a_1	a_2
according to NDS	7D	4D	3D	3D	4D	4D
according to ETA-12/0373	12D	7D	5D	3D	10D	3D

Generally, for screws applied in CLT a minimum thickness of the CLT of 10D is required. According to ETA-12/0373:2022 a minimum embedded thread length of 10D is required in the narrow edge of CLT.

Metal/wood connections

Recommendations base on ETA-12/0373 and are in accordance with ICC-ESR 4549

Acc. to ICC-ESR-4549 steel plate thicknesses $t_{s,s}$ of at least 0.236 in (6.0 mm) are applied. Reference values for the calculation of steel-to-wood connections can be taken from the tables in this brochure or determined in accordance with NDS and ICC-ESR-4549. The capacity of the steel elements must be verified separately according to corresponding standards.

Schmid Schrauben Hainfeld recommend drilling a cylindrical hole in the metal with a diameter of D_{steel} , where the diameter should be a maximum of $D_{steel} + 0.04$ in. For convenience, we have listed common drill sizes in the tables, but the hole in the metal can be made in other ways too.

The RAPID® Dual and SuperSenkFix heads are designed especially for application in metal-to-wood connections. The screw automatically centres in the hole during screwing in and results in a perfect fit.

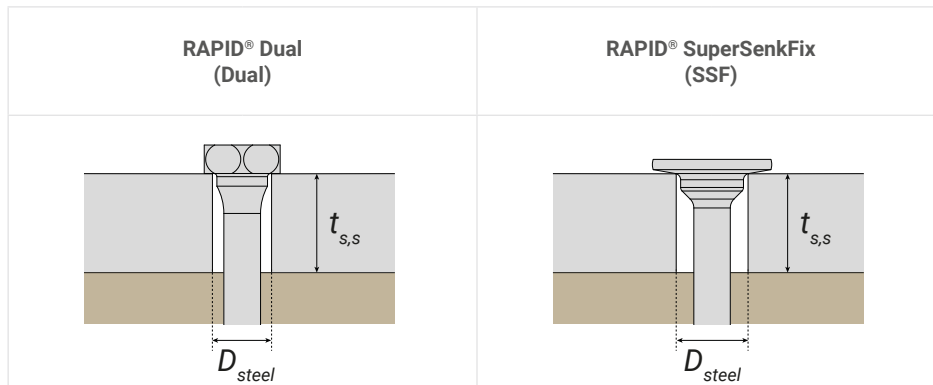

screw size D_{nom}	RAPID® Dual (Dual)		RAPID® SuperSenkFix (SSF)	
	D_{steel}	drill size	D_{steel}	drill size
1/4" (6 mm)	-	-	0.331 in	11/32"
5/16" (8 mm)	0.320 in	11/32"	0.413 in	27/64"
3/8" (10 mm)	0.400 in	27/64"	0.537 in	17/32"
1/2" (12 mm)	0.480 in	1/2"	-	-



90° COUNTERSUNK BORE HOLES: provide the RAPID® Countersunk head with sufficient support on the chamfer. The screw automatically centres while screwing in.

RAPID® countersunk head (CS)
recommended cylindrical bore hole diameter $D_{steel} \geq D$
and chamfer diameter $D_{chamfer}$

screw size D_{nom}	min. $D_{chamfer}$	D_{steel}	drill size
1/4" (6 mm)	0.591 in (15 mm)	0.236 in	1/4"
5/16" (8 mm)	0.748 in (19 mm)	0.315 in	21/64"
3/8" (10 mm)	0.906 in (23 mm)	0.394 in	13/32"
1/2" (12 mm)	0.984 in (25 mm)	0.472 in	1/2"

RAPID® countersunk head (CS)
recommended cylindrical bore hole diameter $D_{steel} \geq D$
and chamfer diameter $D_{chamfer} \geq D_H$

$s \geq 0.118$ in for $\alpha > 45^\circ$
 $s \geq 0.079$ in for $30^\circ \leq \alpha \leq 45^\circ$

screw size D_{nom}	D_H	D_{steel}	drill size
1/4" (6 mm)	0.472 in (12 mm)	0.236 in	1/4"
5/16" (8 mm)	0.591 in (15 mm)	0.315 in	21/64"
3/8" (10 mm)	0.728 in (18.5 mm)	0.394 in	13/32"
1/2" (12 mm)	0.827 in (21 mm)	0.472 in	1/2"



Grand Palais Éphémère

Screw production

FROM WIRE TO SCREW

The RAPID® screws are made from special carbon steel wire. The wire is wound onto spools and then drawn to the desired diameter. In a heading machine, the wire material is cut into blanks of the desired length and then cold-formed, shaping them into the basic screw head configuration. After cold heading, the bolts undergo thread rolling to finalize the screw's geometry.

SCAN TO WATCH
THE VIDEO:



HARDENING - AN IMPORTANT STEP

The screws are subjected to a special heat treatment process so that they can deliver their high performance. This means that they can withstand high tensile loads, but are still very ductile and tough. RAPID® screws can be bent by more than 45° without cracking or breaking. The screws are then sent to the electroplating for the coating treatment.

HYDROGEN EMBRITTLEMENT - NOT WITH US

Thanks to years of experience, we have stable processes for forming, hardening and coating. Together with our partners, we always take care to avoid hydrogen embrittlement in all processes, especially in hardening and electroplating. We are also involved in several projects in partnership with recognized universities, aimed at developing and establishing suitable standards to prevent hydrogen embrittlement.

COATINGS - NOW IT'S GETTING COLORFUL

After hardening, the screws are sent to electroplating, where different coatings (YellWin, BlueWin) can be applied. Using an electroplating process, they are galvanized in different layer thicknesses and then the color (eg. yellow, blue) is passivated or thick-film passivated. Each screw is finished with a sliding coating to ensure low-friction screwing.

QUALITY CONTROL

All screws undergo continuous testing during the production process. For example, the geometry is measured, the mechanical properties are checked after hardening and the coating is checked after the electroplating process. The screws are only packaged ready for dispatch once all checks have been passed.



Corrosion resistance & intended application

Depending on the designation, the screws are provided with different levels of corrosion resistance. The type of coating for each type of screw can be seen on the pages of the individual products (tables with the technical values).

The corrosion resistance is verified through the salt spray test in accordance with EN ISO 9227. Under standard conditions, the specimens are placed in a test chamber where a saline solution (typically a

solution of sodium chloride) is sprayed on them. The examination is limited by a previously determined test period, ranging from a few- to several thousand hours. At the end of the test period, the corrosion phenomena occurring on the test specimens are assessed as white and red rust.

The following illustrates how long the coatings protect the RAPID® screws against the standardized corrosive salt atmosphere without rusting red on the head:

YELLWIN*
Color: **yellow**
Corrosion-resistant: **approx. 100 h**

YELLWIN 500+
Color: **yellow**
Corrosion-resistant: **approx. 500 h**

BLUEWIN
Color: **blue**
Corrosion-resistant: **approx. 50 h**

BLUEWIN 700+
Color: **blue**
Corrosion-resistant: **approx. 700 h**

ZNNI 1000+ *
Color: **gray**
Corrosion-resistant: **approx. 1000 h**

ZNNI 1500+ *
Color: **gray**
Corrosion-resistant: **approx. 1500 h**

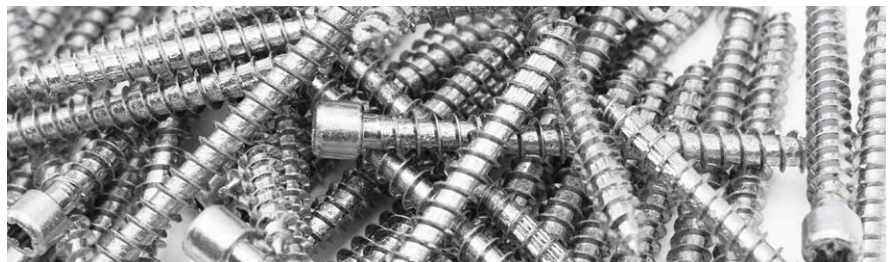

INTENDED APPLICATION – WHERE CAN RAPID® SCREWS BE USED?

The following applies to all our carbon steel screws:

RAPID® screws are suitable for use in dry conditions with a wood moisture content of less than 19 %, as specified by the NDS standards. These conditions are typically met in indoor environments or areas protected by a roof. For wood with a pH value below 4, we recommend ensuring that the wood moisture content remains below 16 %. Please also observe the instructions of the ESR-4549 and the national standards.

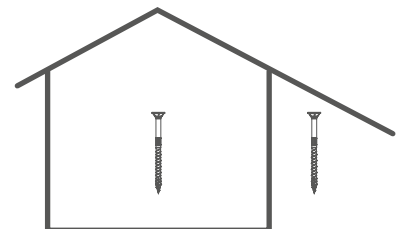

Attention, it is important to ensure dry conditions for all materials – such as wood and screws – even during the installation, including transport and storage at construction site. They have to be protected from excessive moisture.

* available on request

1/4" RAPID® partial thread countersunk head

T-drive (T30), countersunk head, milling pockets, friction part ($\leq 2\text{-}3/8"$ without friction part), HiLo thread, ridged core, YellWin 500+ coating



D_{nom}	D	D_H	D_r	D_s	N_a	N_u	$F_{yb,spec}^{1)}$
in (mm)	in	in	in	in	lbf	lbf	psi
1/4" (6)	0.236	0.472	0.157	0.169	1,270	1,900	208,700

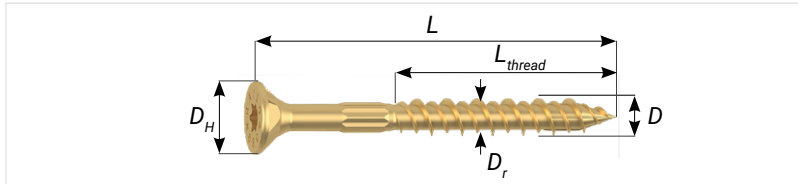

	$L_{emb,w}$	W_{90}	W_H
	in	lbf/in	lbf
SG _{NDS} 0.42	≥ 1.57	112	146
	≥ 2.75	125	
SG _{NDS} 0.50	≥ 1.57	148	-
	≥ 2.76	159	
LVL of DFir* SG _{eg} = 0.50	≥ 1.57	136	188
	≥ 2.76	167	

* acc. to ESR-1040

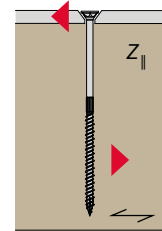
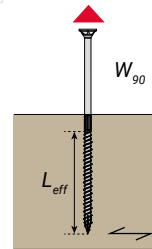
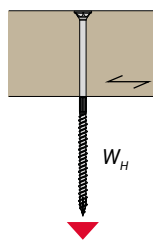
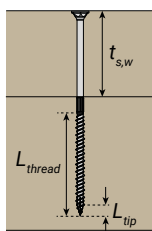

$D_{nom} = 1/4"$ (6 mm)					AXIAL ^{2) 5)}					LATERAL ³⁾	
					HEAD PULL THROUGH		WITHDRAWAL			STEEL-TO-WOOD ⁴⁾	
L		L_{thread}		$L_{thread} = L_{eff}$	W_H		W_{90}			$Z_{ }$	
					SG _{NDS} 0.42	LVL of DFir* SG _{eg} = 0.50	SG _{NDS} 0.42	SG _{NDS} 0.50	LVL of DFir* SG _{eg} = 0.50	SG _{NDS} 0.42	SG _{NDS} 0.50
in	(mm)	in	(mm)	in	lbf	lbf	lbf	lbf	lbf	lbf	lbf
2"	(50)	1-3/16"	(30)	1.18	146	188	-	-	-	198	249
2-3/8"	(60)	1-1/2"	(40)	1.57	146	188	176	232	214	225	273
2-3/4"	(70)	1-1/2"	(40)	1.57	146	188	176	232	214	237	273
3-1/8"	(80)	2"	(50)	1.97	146	188	221	292	268	237	273
3-1/2"	(90)	2"	(50)	1.97	146	188	221	292	268	237	273
4"	(100)	2-3/8"	(60)	2.36	146	188	264	349	321	237	273
4-3/8"	(110)	2-3/8"	(60)	2.36	146	188	264	349	321	237	273
4-3/4"	(120)	2-3/4"	(70)	2.76	146	188	345	439	461	237	273
5-1/8"	(130)	2-3/4"	(70)	2.76	146	188	345	439	461	237	273
5-1/2"	(140)	2-3/4"	(70)	2.76	146	188	345	439	461	237	273
6"	(150)	2-3/4"	(70)	2.76	146	188	345	439	461	237	273
6-1/4"	(160)	2-3/4"	(70)	2.76	146	188	345	439	461	237	273
7-1/8"	(180)	2-3/4"	(70)	2.76	146	188	345	439	461	237	273
7-7/8"	(200)	2-3/4"	(70)	2.76	146	188	345	439	461	237	273
8-5/8"	(220)	2-3/4"	(70)	2.76	146	188	345	439	461	237	273
9-1/2"	(240)	2-3/4"	(70)	2.76	146	188	345	439	461	237	273
10-1/4"	(260)	2-3/4"	(70)	2.76	146	188	345	439	461	237	273
11"	(280)	2-3/4"	(70)	2.76	146	188	345	439	461	237	273
11-3/4"	(300)	2-3/4"	(70)	2.76	146	188	345	439	461	237	273

¹⁾ Minimum specified bending yield strength, determined in acc. with ASTM F1575 using D_r .
²⁾ For axial capacity determine the minimum of the corresponding adjusted values, $\min\{W_H, N\}$; in case of $\alpha < 90^\circ$ apply factor R_α .
³⁾ reference lateral design values for single shear connection with loading parallel to grain (dowel bearing strength $F_{e,||}$) and perpendicular to grain ($F_{e,\perp}$), determined with D_r .
⁴⁾ Assumed steel plate thickness $t_{s,s} = 0.236$ in; the steel plate has to be verified separately

and according to corresponding steel standards.
⁵⁾ Values for threaded length completely located in lower component and equal specific gravity of both members.
 Typos and printing errors reserved. The values stated in combination with geometric requirements, instruction and all further notes are meant to serve as planning guides; projects should only be undertaken by authorised designers and professionals.

1/4" RAPID® partial thread countersunk head

T-drive (T30), countersunk head, milling pockets, friction part ($\leq 2\text{-}3/8"$ without friction part), HiLo thread, ridged core, YellWin 500+ coating



D_{nom}	D	D_H	D_r	D_s	N_a	N_u	$F_{yb,spec}^{1)}$
in (mm)	in	in	in	in	lbf	lbf	psi
1/4" (6)	0.236	0.472	0.157	0.169	1,270	1,900	208,700

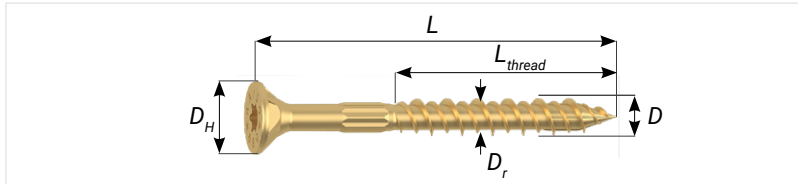

	$L_{emb,w}$	W_{90}	W_H
	in	lbf/in	lbf
$SG_{NDS} 0.42$	≥ 1.57	112	146
	≥ 2.75	125	
$SG_{NDS} 0.50$	≥ 1.57	148	-
	≥ 2.76	159	
LVL of DFir* $SG_{eg} = 0.50$	≥ 1.57	136	188
	≥ 2.76	167	

* acc. to ESR-1040

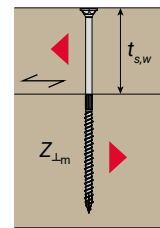
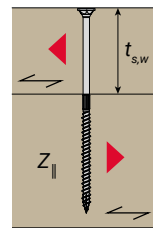
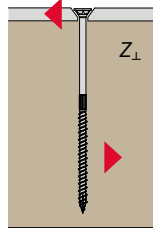
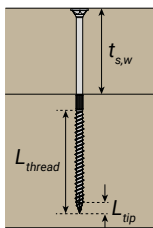

$D_{nom} = 1/4"$ (6 mm)				LATERAL ³⁾						
				STEEL-TO-WOOD ⁴⁾		$t_{s,w}$	WOOD-TO-WOOD ⁵⁾		WOOD-TO-WOOD ⁵⁾	
L		L_{thread}		Z_{\perp}			$t_{s,w}$	$Z_{ }$		$Z_{ ,m}$
				$SG_{NDS} 0.42$	$SG_{NDS} 0.50$	$SG_{NDS} 0.42$		$SG_{NDS} 0.50$	$SG_{NDS} 0.42$	$SG_{NDS} 0.50$
in	(mm)	in	(mm)	lbf	lbf	in	lbf	lbf	lbf	lbf
2"	(50)	1-3/16"	(30)	198	249	-	-	-	-	-
2-3/8"	(60)	1-1/2"	(40)	225	273	-	-	-	-	-
2-3/4"	(70)	1-1/2"	(40)	237	273	-	-	-	-	-
3-1/8"	(80)	2"	(50)	237	273	-	-	-	-	-
3-1/2"	(90)	2"	(50)	237	273	-	-	-	-	-
4"	(100)	2-3/8"	(60)	237	273	-	-	-	-	-
4-3/8"	(110)	2-3/8"	(60)	237	273	-	-	-	-	-
4-3/4"	(120)	2-3/4"	(70)	237	273	-	-	-	-	-
5-1/8"	(130)	2-3/4"	(70)	237	273	-	-	-	-	-
5-1/2"	(140)	2-3/4"	(70)	237	273	-	-	-	-	-
6"	(150)	2-3/4"	(70)	237	273	-	-	-	-	-
6-1/4"	(160)	2-3/4"	(70)	237	273	3-1/2"	171	201	171	201
7-1/8"	(180)	2-3/4"	(70)	237	273	3-1/2"	171	201	171	201
7-7/8"	(200)	2-3/4"	(70)	237	273	3-1/2"	171	201	171	201
8-5/8"	(220)	2-3/4"	(70)	237	273	3-1/2"	171	201	171	201
9-1/2"	(240)	2-3/4"	(70)	237	273	3-1/2"	171	201	171	201
10-1/4"	(260)	2-3/4"	(70)	237	273	3-1/2"	171	201	171	201
11"	(280)	2-3/4"	(70)	237	273	3-1/2"	171	201	171	201
11-3/4"	(300)	2-3/4"	(70)	237	273	3-1/2"	171	201	171	201

¹⁾ Minimum specified bending yield strength, determined in acc. with ASTM F1575 using D_r .
²⁾ For axial capacity determine the minimum of the corresponding adjusted values, $\min\{W_H, N\}$; in case of $\alpha < 90^\circ$ apply factor R_α .
³⁾ reference lateral design values for single shear connection with loading parallel to grain (dowel bearing strength $F_{e||}$) and perpendicular to grain ($F_{e\perp}$), determined with D_r .
⁴⁾ Assumed steel plate thickness $t_{s,s} = 0.236$ in; the steel plate has to be verified separately

and according to corresponding steel standards.
⁵⁾ Values for threaded length completely located in lower component and equal specific gravity of both members.
 Typos and printing errors reserved. The values stated in combination with geometric requirements, instruction and all further notes are meant to serve as planning guides; projects should only be undertaken by authorised designers and professionals.

5/16" RAPID® partial thread countersunk head

T-drive (T40), countersunk head, milling pockets, friction part, HiLo thread, ridged core, YellWin 500+ coating



D_{nom}	D	D_H	D_r	D_s	N_a	N_u	$F_{yb,spec}^{1)}$
in (mm)	in	in	in	in	lbf	lbf	psi
5/16" (8)	0.315	0.591	0.210	0.232	2,100	3,160	142,000

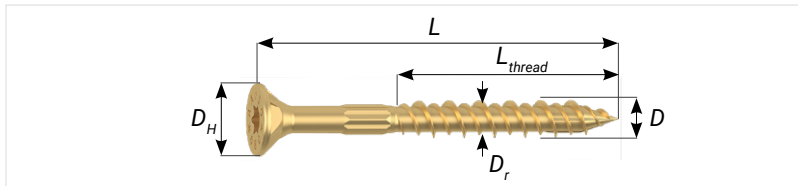

	$L_{emb,w}$	W_{90}	W_H
	in	lbf/in	lbf
SG _{NDS} 0.42	≥ 1.18	107	205
	≥ 3.98	162	
SG _{NDS} 0.50	≥ 1.06	164	-
	≥ 3.94	198	
LVL of DFir* SG _{eg} = 0.50	≥ 1.06	141	280
	≥ 3.94	199	

* acc. to ESR-1040

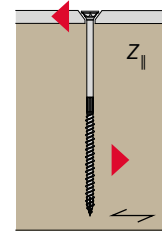
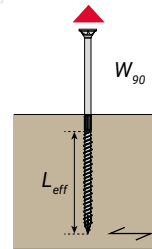
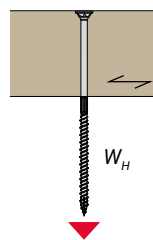
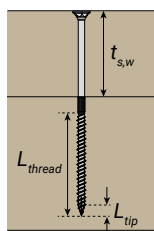

$D_{nom} = 5/16"$ (8 mm)					AXIAL ^{2) 5)}					LATERAL ³⁾	
					HEAD PULL THROUGH		WITHDRAWAL			STEEL-TO-WOOD ⁴⁾	
L		L_{thread}		$L_{thread} = L_{eff}$	W_H		W_{90}			$Z_{ }$	
					SG _{NDS} 0.42	LVL of DFir* SG _{eg} = 0.50	SG _{NDS} 0.42	SG _{NDS} 0.50	LVL of DFir* SG _{eg} = 0.50	SG _{NDS} 0.42	SG _{NDS} 0.50
in	(mm)	in	(mm)	in	lbf	lbf	lbf	lbf	lbf	lbf	lbf
3-1/8"	(80)	2"	(50)	1.97	205	280	211	323	278	282	324
3-1/2"	(90)	2"	(50)	1.97	205	280	211	323	278	282	324
4"	(100)	2-3/8"	(60)	2.36	205	280	253	387	333	282	324
4-3/4"	(120)	3-1/8"	(80)	3.15	205	280	337	517	444	282	324
5-1/2"	(140)	3-1/8"	(80)	3.15	205	280	337	517	444	282	324
6-1/4"	(160)	3-1/8"	(80)	3.15	205	280	337	517	444	282	324
7-1/8"	(180)	4"	(100)	3.98	205	280	645	788	792	282	324
7-7/8"	(200)	4"	(100)	3.98	205	280	645	788	792	282	324
8-5/8"	(220)	4"	(100)	3.98	205	280	645	788	792	282	324
9-1/2"	(240)	4"	(100)	3.98	205	280	645	788	792	282	324
10-1/4"	(260)	4"	(100)	3.98	205	280	645	788	792	282	324
11"	(280)	4"	(100)	3.98	205	280	645	788	792	282	324
11-3/4"	(300)	4"	(100)	3.98	205	280	645	788	792	282	324
12-5/8"	(320)	4"	(100)	3.98	205	280	645	788	792	282	324
13-3/8"	(340)	4"	(100)	3.98	205	280	645	788	792	282	324
14-1/8"	(360)	4"	(100)	3.98	205	280	645	788	792	282	324
15"	(380)	4"	(100)	3.98	205	280	645	788	792	282	324
15-3/4"	(400)	4"	(100)	3.98	205	280	645	788	792	282	324
16-1/2"	(420)	4"	(100)	3.98	205	280	645	788	792	282	324
17-5/8"	(440)	4"	(100)	3.98	205	280	645	788	792	282	324
18-1/8"	(460)	4"	(100)	3.98	205	280	645	788	792	282	324
18-7/8"	(480)	4"	(100)	3.98	205	280	645	788	792	282	324
19-5/8"	(500)	4"	(100)	3.98	205	280	645	788	792	282	324

¹⁾ Minimum specified bending yield strength, determined in acc. with ASTM F1575 using D_r .
²⁾ For axial capacity determine the minimum of the corresponding adjusted values, $\min\{W_H, N_a, N_u\}$; in case of $\alpha < 90^\circ$ apply factor R_α .
³⁾ reference lateral design values for single shear connection with loading parallel to grain (dowel bearing strength $F_{e,||}$) and perpendicular to grain ($F_{e,\perp}$), determined with D_r .
⁴⁾ Assumed steel plate thickness $t_{s,s} = 0.236$ in; the steel plate has to be verified separately

and according to corresponding steel standards.
⁵⁾ Values for threaded length completely located in lower component and equal specific gravity of both members.
 Typos and printing errors reserved. The values stated in combination with geometric requirements, instruction and all further notes are meant to serve as planning guides; projects should only be undertaken by authorised designers and professionals.

5/16" RAPID® partial thread countersunk head

T-drive (T40), countersunk head, milling pockets, friction part, HiLo thread, ridged core, YellWin 500+ coating



D_{nom}	D	D_H	D_r	D_s	N_a	N_u	$F_{yb,spec}^{1)}$
in (mm)	in	in	in	in	lbf	lbf	psi
5/16" (8)	0.315	0.591	0.210	0.232	2,100	3,160	142,000

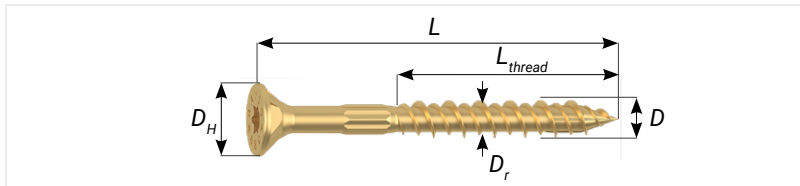

	$L_{emb,w}$	W_{90}	W_H
	in	lbf/in	lbf
$SG_{NDS} 0.42$	≥ 1.18	107	205
	≥ 3.98	162	
$SG_{NDS} 0.50$	≥ 1.06	164	-
	≥ 3.94	198	
LVL of DFir* $SG_{eg} = 0.50$	≥ 1.06	141	280
	≥ 3.94	199	

* acc. to ESR-1040

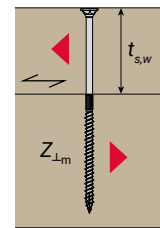
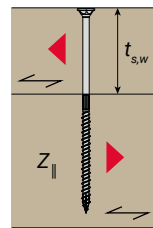
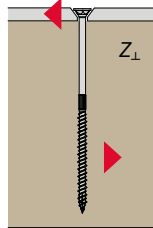
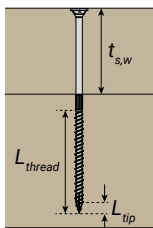

$D_{nom} = 5/16"$ (8 mm)				LATERAL ³⁾							
				STEEL-TO-WOOD ⁴⁾				WOOD-TO-WOOD ⁵⁾			
L		L_{thread}		Z_{\perp}		$t_{s,w}$	Z_{\parallel}		$Z_{\perp,m}$		
				$SG_{NDS} 0.42$	$SG_{NDS} 0.50$		$SG_{NDS} 0.42$	$SG_{NDS} 0.50$	$SG_{NDS} 0.42$	$SG_{NDS} 0.50$	
in	(mm)	in	(mm)	lbf	lbf	in	lbf	lbf	lbf	lbf	
3-1/8"	(80)	2"	(50)	225	259	-	-	-	-	-	
3-1/2"	(90)	2"	(50)	225	259	-	-	-	-	-	
4"	(100)	2-3/8"	(60)	225	259	-	-	-	-	-	
4-3/4"	(120)	3-1/8"	(80)	225	259	-	-	-	-	-	
5-1/2"	(140)	3-1/8"	(80)	225	259	-	-	-	-	-	
6-1/4"	(160)	3-1/8"	(80)	225	259	-	-	-	-	-	
7-1/8"	(180)	4"	(100)	225	259	-	-	-	-	-	
7-7/8"	(200)	4"	(100)	225	259	3-1/2"	214	251	171	201	
8-5/8"	(220)	4"	(100)	225	259	3-1/2"	214	251	171	201	
9-1/2"	(240)	4"	(100)	225	259	3-1/2"	214	251	171	201	
10-1/4"	(260)	4"	(100)	225	259	3-1/2"	214	251	171	201	
11"	(280)	4"	(100)	225	259	3-1/2"	214	251	171	201	
11-3/4"	(300)	4"	(100)	225	259	3-1/2"	214	251	171	201	
12-5/8"	(320)	4"	(100)	225	259	3-1/2"	214	251	171	201	
13-3/8"	(340)	4"	(100)	225	259	3-1/2"	214	251	171	201	
14-1/8"	(360)	4"	(100)	225	259	3-1/2"	214	251	171	201	
15"	(380)	4"	(100)	225	259	3-1/2"	214	251	171	201	
15-3/4"	(400)	4"	(100)	225	259	3-1/2"	214	251	171	201	
16-1/2"	(420)	4"	(100)	225	259	3-1/2"	214	251	171	201	
17-5/8"	(440)	4"	(100)	225	259	3-1/2"	214	251	171	201	
18-1/8"	(460)	4"	(100)	225	259	3-1/2"	214	251	171	201	
18-7/8"	(480)	4"	(100)	225	259	3-1/2"	214	251	171	201	
19-5/8"	(500)	4"	(100)	225	259	3-1/2"	214	251	171	201	

¹⁾ Minimum specified bending yield strength, determined in acc. with ASTM F1575 using D_r .
²⁾ For axial capacity determine the minimum of the corresponding adjusted values, $\min\{W; W_H; N\}$; in case of $\alpha < 90^\circ$ apply factor R_{α} .
³⁾ reference lateral design values for single shear connection with loading parallel to grain (dowel bearing strength F_{e1}) and perpendicular to grain (F_{e2}), determined with D_r .
⁴⁾ Assumed steel plate thickness $t_{s,s} = 0.236$ in; the steel plate has to be verified separately

and according to corresponding steel standards.
⁵⁾ Values for threaded length completely located in lower component and equal specific gravity of both members.
 Typos and printing errors reserved. The values stated in combination with geometric requirements, instruction and all further notes are meant to serve as planning guides; projects should only be undertaken by authorised designers and professionals.

3/8" RAPID® partial thread countersunk head

T-drive (T50), countersunk head, milling ribs, friction part, HiLo thread, ridged core, YellWin 500+ coating



D_{nom}	D	D_H	D_r	D_s	N_a	N_u	$F_{yb,spec}^{1)}$
in (mm)	in	in	in	in	lbf	lbf	psi
3/8" (10)	0.394	0.728	0.244	0.280	3,540	5,310	174,300

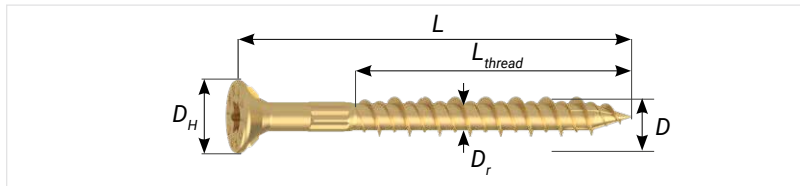

	$L_{emb,w}$	W_{90}	W_H
	in	lbf/in	lbf
SG _{NDS} 0.42	≥ 1.97	147	287
	≥ 3.98	180	
SG _{NDS} 0.50	≥ 1.77	213	-
	≥ 3.74	249	
LVL of DFir* SG _{eg} = 0.50	≥ 1.97	181	416
	≥ 3.74	212	

* acc. to ESR-1040

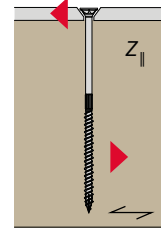
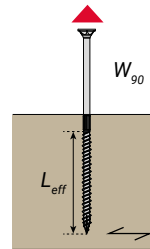
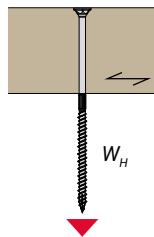
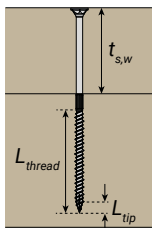

$D_{nom} = 3/8"$ (10 mm)					AXIAL ^{2) 5)}					LATERAL ³⁾	
					HEAD PULL THROUGH		WITHDRAWAL			STEEL-TO-WOOD ⁴⁾	
L		L_{thread}		$L_{thread} = L_{eff}$	W_H		W_{90}			$Z_{ }$	
					SG _{NDS} 0.42	LVL of DFir* SG _{eg} = 0.50	SG _{NDS} 0.42	SG _{NDS} 0.50	LVL of DFir* SG _{eg} = 0.50	SG _{NDS} 0.42	SG _{NDS} 0.50
in	(mm)	in	(mm)	in	lbf	lbf	lbf	lbf	lbf	lbf	lbf
3-1/8"	(80)	2"	(50)	1.97	-	-	290	420	357	323	386
4"	(100)	2-3/8"	(60)	2.36	287	416	347	503	427	335	386
4-3/4"	(120)	3-1/8"	(80)	3.15	287	416	463	671	570	335	386
5-1/2"	(140)	3-1/8"	(80)	3.15	287	416	463	671	570	335	386
6-1/4"	(160)	3-1/8"	(80)	3.15	287	416	463	671	570	335	386
7-1/8"	(180)	4"	(100)	3.98	287	416	716	991	844	335	386
7-7/8"	(200)	4"	(100)	3.98	287	416	716	991	844	335	386
8-5/8"	(220)	4"	(100)	3.98	287	416	716	991	844	335	386
9-1/2"	(240)	4"	(100)	3.98	287	416	716	991	844	335	386
10-1/4"	(260)	4"	(100)	3.98	287	416	716	991	844	335	386
11"	(280)	4"	(100)	3.98	287	416	716	991	844	335	386
11-3/4"	(300)	4"	(100)	3.98	287	416	716	991	844	335	386
12-5/8"	(320)	4"	(100)	3.98	287	416	716	991	844	335	386
13-3/8"	(340)	4"	(100)	3.98	287	416	716	991	844	335	386
14-1/8"	(360)	4"	(100)	3.98	287	416	716	991	844	335	386
15"	(380)	4"	(100)	3.98	287	416	716	991	844	335	386
15-3/4"	(400)	4"	(100)	3.98	287	416	716	991	844	335	386
16-1/2"	(420)	4"	(100)	3.98	287	416	716	991	844	335	386
17-5/8"	(440)	4"	(100)	3.98	287	416	716	991	844	335	386
18-1/8"	(460)	4"	(100)	3.98	287	416	716	991	844	335	386
18-7/8"	(480)	4"	(100)	3.98	287	416	716	991	844	335	386
19-5/8"	(500)	4"	(100)	3.98	287	416	716	991	844	335	386

¹⁾ Minimum specified bending yield strength, determined in acc. with ASTM F1575 using D_r .
²⁾ For axial capacity determine the minimum of the corresponding adjusted values, $\min\{W_H, N\}$; in case of $\alpha < 90^\circ$ apply factor R_α .
³⁾ reference lateral design values for single shear connection with loading parallel to grain (dowel bearing strength F_{e1}) and perpendicular to grain (F_{e2}), determined with D_r .
⁴⁾ Assumed steel plate thickness $t_{s,s} = 0.236$ in; the steel plate has to be verified separately

and according to corresponding steel standards.
⁵⁾ Values for threaded length completely located in lower component and equal specific gravity of both members.
 Typos and printing errors reserved. The values stated in combination with geometric requirements, instruction and all further notes are meant to serve as planning guides; projects should only be undertaken by authorised designers and professionals.

3/8" RAPID® partial thread countersunk head

T-drive (T50), countersunk head, milling ribs, friction part, HiLo thread, ridged core, YellWin 500+ coating



D_{nom}	D	D_H	D_r	D_s	N_a	N_u	$F_{yb,spec}^{1)}$
in (mm)	in	in	in	in	lbf	lbf	psi
3/8" (10)	0.394	0.728	0.244	0.280	3,540	5,310	174,300

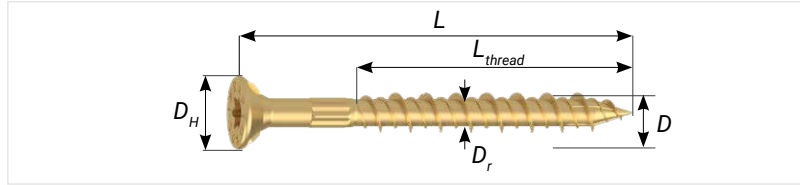

	$L_{emb,w}$	W_{90}	W_H
	in	lbf/in	lbf
$SG_{NDS} 0.42$	≥ 1.97	147	287
	≥ 3.98	180	
$SG_{NDS} 0.50$	≥ 1.77	213	-
	≥ 3.74	249	
LVL of DFir* $SG_{eg} = 0.50$	≥ 1.97	181	416
	≥ 3.74	212	

* acc. to ESR-1040

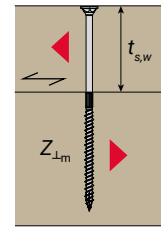
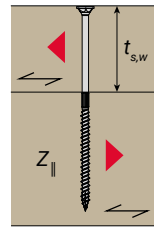
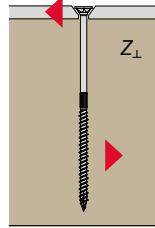
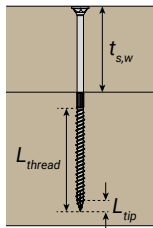

$D_{nom} = 3/8"$ (10 mm)				LATERAL ³⁾							
				STEEL-TO-WOOD ⁴⁾				WOOD-TO-WOOD ⁵⁾			
L		L_{thread}		Z_{\perp}		$t_{s,w}$	Z_{\parallel}		$Z_{\perp,m}$		
				$SG_{NDS} 0.42$	$SG_{NDS} 0.50$		$SG_{NDS} 0.42$	$SG_{NDS} 0.50$	$SG_{NDS} 0.42$	$SG_{NDS} 0.50$	
in	(mm)	in	(mm)	lbf	lbf	in	lbf	lbf	lbf	lbf	
3-1/8"	(80)	2"	(50)	259	309	-	-	-	-	-	
4"	(100)	2-3/8"	(60)	268	309	-	-	-	-	-	
4-3/4"	(120)	3-1/8"	(80)	268	309	-	-	-	-	-	
5-1/2"	(140)	3-1/8"	(80)	268	309	-	-	-	-	-	
6-1/4"	(160)	3-1/8"	(80)	268	309	-	-	-	-	-	
7-1/8"	(180)	4"	(100)	268	309	-	-	-	-	-	
7-7/8"	(200)	4"	(100)	268	309	3-1/2"	283	332	222	266	
8-5/8"	(220)	4"	(100)	268	309	3-1/2"	283	332	222	266	
9-1/2"	(240)	4"	(100)	268	309	3-1/2"	283	332	222	266	
10-1/4"	(260)	4"	(100)	268	309	3-1/2"	283	332	222	266	
11"	(280)	4"	(100)	268	309	3-1/2"	283	332	222	266	
11-3/4"	(300)	4"	(100)	268	309	3-1/2"	283	332	222	266	
12-5/8"	(320)	4"	(100)	268	309	3-1/2"	283	332	222	266	
13-3/8"	(340)	4"	(100)	268	309	3-1/2"	283	332	222	266	
14-1/8"	(360)	4"	(100)	268	309	3-1/2"	283	332	222	266	
15"	(380)	4"	(100)	268	309	3-1/2"	283	332	222	266	
15-3/4"	(400)	4"	(100)	268	309	3-1/2"	283	332	222	266	
16-1/2"	(420)	4"	(100)	268	309	3-1/2"	283	332	222	266	
17-5/8"	(440)	4"	(100)	268	309	3-1/2"	283	332	222	266	
18-1/8"	(460)	4"	(100)	268	309	3-1/2"	283	332	222	266	
18-7/8"	(480)	4"	(100)	268	309	3-1/2"	283	332	222	266	
19-5/8"	(500)	4"	(100)	268	309	3-1/2"	283	332	222	266	

¹⁾ Minimum specified bending yield strength, determined in acc. with ASTM F1575 using D_r .
²⁾ For axial capacity determine the minimum of the corresponding adjusted values, $\min\{W; W_H; N\}$; in case of $\alpha < 90^\circ$ apply factor R_α ;
³⁾ reference lateral design values for single shear connection with loading parallel to grain (dowel bearing strength $F_{e\parallel}$) and perpendicular to grain ($F_{e\perp}$), determined with D_r .
⁴⁾ Assumed steel plate thickness $t_{s,s} = 0.236$ in; the steel plate has to be verified separately

and according to corresponding steel standards.
⁵⁾ Values for threaded length completely located in lower component and equal specific gravity of both members.
 Typos and printing errors reserved. The values stated in combination with geometric requirements, instruction and all further notes are meant to serve as planning guides; projects should only be undertaken by authorised designers and professionals.

1/2" RAPID® partial thread countersunk head

T-drive (T50), countersunk head, milling ribs, friction part, single thread, ridged core, YellWin 500+ coating



D_{nom}	D	D_H	D_r	D_s	N_a	N_u	$F_{yb,spec}^{1)}$
in (mm)	in	in	in	in	lbf	lbf	psi
1/2" (12)	0.472	0.827	0.268	0.323	3,900	5,820	192,900

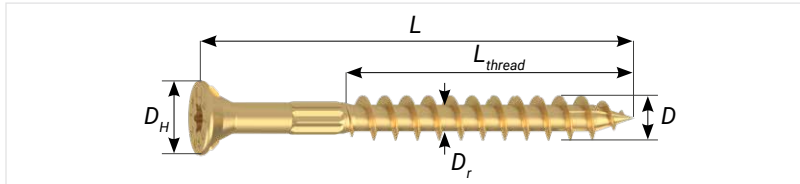

	$L_{emb,w}$	W_{90}	W_H
	in	lbf/in	lbf
SG _{NDS} 0.42	≥ 1.97	194	301
	≥ 4.72	219	
SG _{NDS} 0.50	≥ 1.97	232	-
	≥ 4.72	296	
LVL of DFir* SG _{eg} = 0.50	≥ 1.97	201	426
	≥ 4.72	249	

* acc. to ESR-1040

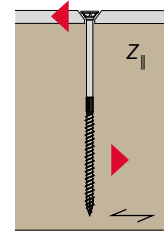
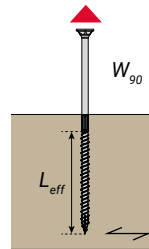
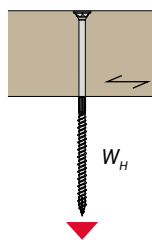
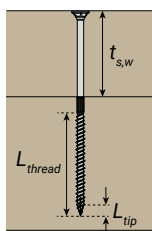

$D_{nom} = 1/2"$ (12 mm)					AXIAL ^{2) 5)}					LATERAL ³⁾	
					HEAD PULL THROUGH		WITHDRAWAL			STEEL-TO-WOOD ⁴⁾	
L		L_{thread}		$L_{thread} = L_{eff}$	W_H		W_{90}			$Z_{ }$	
					SG _{NDS} 0.42	LVL of DFir* SG _{eg} = 0.50	SG _{NDS} 0.42	SG _{NDS} 0.50	LVL of DFir* SG _{eg} = 0.50	SG _{NDS} 0.42	SG _{NDS} 0.50
in	(mm)	in	(mm)	in	lbf	lbf	lbf	lbf	lbf	lbf	lbf
4"	(100)	2-3/8"	(60)	2.36	301	426	458	548	474	432	467
4-3/4"	(120)	3-1/8"	(80)	3.15	301	426	611	731	633	432	467
5-1/2"	(140)	3-1/8"	(80)	3.15	301	426	611	731	633	432	467
6-1/4"	(160)	3-1/8"	(80)	3.15	301	426	611	731	633	432	467
7-1/8"	(180)	4"	(100)	3.94	301	426	764	914	792	432	467
7-7/8"	(200)	4"	(100)	3.94	301	426	764	914	792	432	467
8-5/8"	(220)	4"	(100)	3.94	301	426	764	914	792	432	467
9-1/2"	(240)	4"	(100)	3.94	301	426	764	914	792	432	467
10-1/4"	(260)	4"	(100)	3.94	301	426	764	914	792	432	467
11"	(280)	4"	(100)	3.94	301	426	764	914	792	432	467
11-3/4"	(300)	4-3/4"	(120)	4.72	301	426	1034	1397	1175	432	467
12-5/8"	(320)	4-3/4"	(120)	4.72	301	426	1034	1397	1175	432	467
13-3/8"	(340)	4-3/4"	(120)	4.72	301	426	1034	1397	1175	432	467
14-1/8"	(360)	4-3/4"	(120)	4.72	301	426	1034	1397	1175	432	467
15"	(380)	4-3/4"	(120)	4.72	301	426	1034	1397	1175	432	467
15-3/4"	(400)	4-3/4"	(120)	4.72	301	426	1034	1397	1175	432	467

¹⁾ Minimum specified bending yield strength, determined in acc. with ASTM F1575 using D_r .
²⁾ For axial capacity determine the minimum of the corresponding adjusted values, $\min\{W_H, N\}$; in case of $\alpha < 90^\circ$ apply factor R_α .
³⁾ reference lateral design values for single shear connection with loading parallel to grain (dowel bearing strength $F_{e||}$) and perpendicular to grain ($F_{e\perp}$), determined with D_r .
⁴⁾ Assumed steel plate thickness $t_{s,s} = 0.236$ in; the steel plate has to be verified separately

and according to corresponding steel standards.
⁵⁾ Values for threaded length completely located in lower component and equal specific gravity of both members.
 Typos and printing errors reserved. The values stated in combination with geometric requirements, instruction and all further notes are meant to serve as planning guides; projects should only be undertaken by authorised designers and professionals.

1/2" RAPID® partial thread countersunk head

T-drive (T50), countersunk head, milling ribs, friction part, single thread, ridged core, YellWin 500+ coating



D_{nom}	D	D_H	D_r	D_s	N_a	N_u	$F_{yb,spec}^{1)}$
in (mm)	in	in	in	in	lbf	lbf	psi
1/2" (12)	0.472	0.827	0.268	0.323	3,900	5,820	192,900

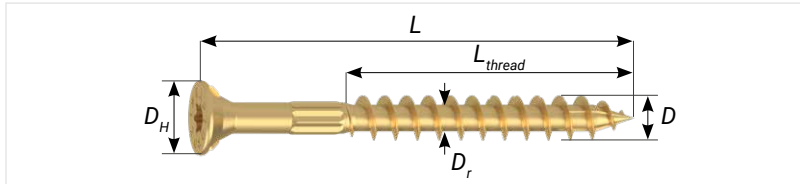

	$L_{emb,w}$	W_{90}	W_H
	in	lbf/in	lbf
$SG_{NDS} 0.42$	≥ 1.97	194	301
	≥ 4.72	219	
$SG_{NDS} 0.50$	≥ 1.97	232	-
	≥ 4.72	296	
LVL of DFir* $SG_{eg} = 0.50$	≥ 1.97	201	426
	≥ 4.72	249	

* acc. to ESR-1040

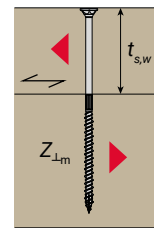
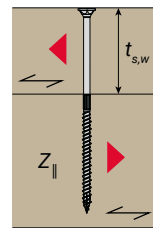
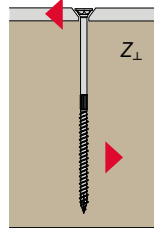
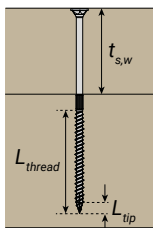

$D_{nom} = 1/2"$ (12 mm)				LATERAL ³⁾						
				STEEL-TO-WOOD ⁴⁾		$t_{s,w}$	WOOD-TO-WOOD ⁵⁾		WOOD-TO-WOOD ⁵⁾	
L	L_{thread}	Z_{\perp}		Z_{\parallel}	$Z_{\perp,m}$		$SG_{NDS} 0.42$	$SG_{NDS} 0.50$		
		$SG_{NDS} 0.42$	$SG_{NDS} 0.50$		$SG_{NDS} 0.42$	$SG_{NDS} 0.50$				
in	(mm)	in	(mm)	lbf	lbf	in	lbf	lbf	lbf	lbf
4"	(100)	2-3/8"	(60)	284	333	-	-	-	-	-
4-3/4"	(120)	3-1/8"	(80)	297	333	-	-	-	-	-
5-1/2"	(140)	3-1/8"	(80)	297	333	-	-	-	-	-
6-1/4"	(160)	3-1/8"	(80)	297	333	-	-	-	-	-
7-1/8"	(180)	4"	(100)	297	333	-	-	-	-	-
7-7/8"	(200)	4"	(100)	297	333	3-1/2"	390	426	285	318
8-5/8"	(220)	4"	(100)	297	333	3-1/2"	390	426	285	318
9-1/2"	(240)	4"	(100)	297	333	3-1/2"	390	426	285	318
10-1/4"	(260)	4"	(100)	297	333	3-1/2"	390	426	285	318
11"	(280)	4"	(100)	297	333	3-1/2"	390	426	285	318
11-3/4"	(300)	4-3/4"	(120)	297	333	3-1/2"	390	426	285	318
12-5/8"	(320)	4-3/4"	(120)	297	333	3-1/2"	390	426	285	318
13-3/8"	(340)	4-3/4"	(120)	297	333	3-1/2"	390	426	285	318
14-1/8"	(360)	4-3/4"	(120)	297	333	3-1/2"	390	426	285	318
15"	(380)	4-3/4"	(120)	297	333	3-1/2"	390	426	285	318
15-3/4"	(400)	4-3/4"	(120)	297	333	3-1/2"	390	426	285	318

¹⁾ Minimum specified bending yield strength, determined in acc. with ASTM F1575 using D_r .
²⁾ For axial capacity determine the minimum of the corresponding adjusted values, $\min\{W_H^*, N\}$; in case of $\alpha < 90^\circ$ apply factor R_α .
³⁾ reference lateral design values for single shear connection with loading parallel to grain (dowel bearing strength $F_{e\parallel}$) and perpendicular to grain ($F_{e\perp}$), determined with D_r .
⁴⁾ Assumed steel plate thickness $t_{s,s} = 0.236$ in; the steel plate has to be verified separately

and according to corresponding steel standards.
⁵⁾ Values for threaded length completely located in lower component and equal specific gravity of both members.
 Typos and printing errors reserved. The values stated in combination with geometric requirements, instruction and all further notes are meant to serve as planning guides; projects should only be undertaken by authorised designers and professionals.

1/4" RAPID® partial thread washer head

T-drive (T30), washer head, friction part, HiLo thread, ridged core, YellWin 500+ coating



D_{nom}	D	D_H	D_r	D_s	N_a	N_u	$F_{yb,spec}^{1)}$
in (mm)	in	in	in	in	lbf	lbf	psi
1/4" (6)	0.236	0.551	0.157	0.169	1,270	1,900	208,700

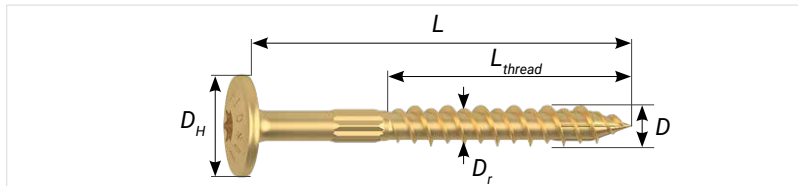

	$L_{emb,w}$	W_{90}	W_H
	in	lbf/in	lbf
SG _{NDS} 0.42	≥ 1.57	112	219
	≥ 2.75	125	
SG _{NDS} 0.50	≥ 1.57	148	221
	≥ 2.76	159	
LVL of DFir* SG _{eg} = 0.50	≥ 1.57	136	239
	≥ 2.76	167	

* acc. to ESR-1040

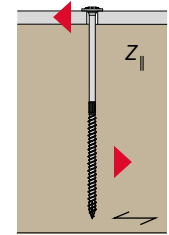
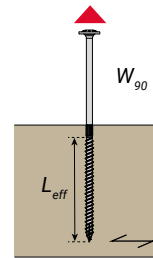
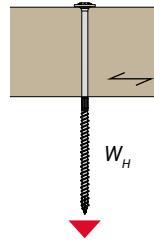
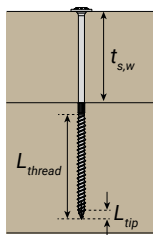

$D_{nom} = 1/4"$ (6 mm)					AXIAL ^{2) 5)}						LATERAL ³⁾	
					HEAD PULL THROUGH			WITHDRAWAL			STEEL-TO-WOOD ⁴⁾	
L		L_{thread}		$L_{thread} = L_{eff}$	W_H			W_{90}			$Z_{ }$	
					SG _{NDS} 0.42	SG _{NDS} 0.50	LVL of DFir* SG _{eg} = 0.50	SG _{NDS} 0.42	SG _{NDS} 0.50	LVL of DFir* SG _{eg} = 0.50	SG _{NDS} 0.42	SG _{NDS} 0.50
in	(mm)	in	(mm)	in	lbf	lbf	lbf	lbf	lbf	lbf	lbf	lbf
2-3/8"	(60)	1-1/2"	(40)	1.57	219	221	176	232	214	214	225	273
3-1/8"	(80)	2"	(50)	1.97	219	221	221	292	268	268	237	273
4"	(100)	2-3/8"	(60)	2.36	219	221	264	349	321	321	237	273
4-3/4"	(120)	2-3/4"	(70)	2.76	219	221	345	439	461	375	237	273
5-1/2"	(140)	2-3/4"	(70)	2.76	219	221	345	439	461	375	237	273
6-1/4"	(160)	2-3/4"	(70)	2.76	219	221	345	439	461	375	237	273
7-1/8"	(180)	2-3/4"	(70)	2.76	219	221	345	439	461	375	237	273
7-7/8"	(200)	2-3/4"	(70)	2.76	219	221	345	439	461	375	237	273
8-5/8"	(220)	2-3/4"	(70)	2.76	219	221	345	439	461	375	237	273
9-1/2"	(240)	2-3/4"	(70)	2.76	219	221	345	439	461	375	237	273
10-1/4"	(260)	2-3/4"	(70)	2.76	219	221	345	439	461	375	237	273
11"	(280)	2-3/4"	(70)	2.76	219	221	345	439	461	375	237	273
11-3/4"	(300)	2-3/4"	(70)	2.76	219	221	345	439	461	375	237	273

¹⁾ Minimum specified bending yield strength, determined in acc. with ASTM F1575 using D_r .
²⁾ For axial capacity determine the minimum of the corresponding adjusted values, $\min\{W_H, N\}$; in case of $\alpha < 90^\circ$ apply factor R_α .
³⁾ reference lateral design values for single shear connection with loading parallel to grain (dowel bearing strength $F_{e,||}$) and perpendicular to grain ($F_{e,\perp}$), determined with D_r .
⁴⁾ Assumed steel plate thickness $t_{s,s} = 0.236$ in; the steel plate has to be verified separately

and according to corresponding steel standards.
⁵⁾ Values for threaded length completely located in lower component and equal specific gravity of both members.
 Typos and printing errors reserved. The values stated in combination with geometric requirements, instruction and all further notes are meant to serve as planning guides; projects should only be undertaken by authorised designers and professionals.

1/4" RAPID® partial thread washer head

T-drive (T30), washer head, friction part, HiLo thread, ridged core, YellWin 500+ coating



D_{nom}	D	D_H	D_r	D_s	N_a	N_u	$F_{yb,spec}^{1)}$
in (mm)	in	in	in	in	lbf	lbf	psi
1/4" (6)	0.236	0.551	0.157	0.169	1,270	1,900	208,700

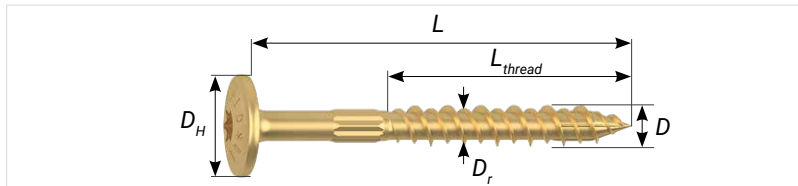

	$L_{emb,w}$	W_{90}	W_H
	in	lbf/in	lbf
SG _{NDS} 0.42	≥ 1.57	112	219
	≥ 2.75	125	
SG _{NDS} 0.50	≥ 1.57	148	221
	≥ 2.76	159	
LVL of DFir* SG _{eg} = 0.50	≥ 1.57	136	239
	≥ 2.76	167	

* acc. to ESR-1040

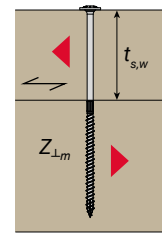
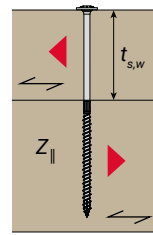
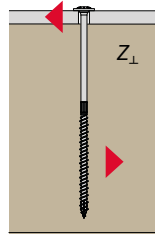
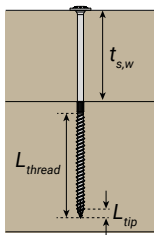

$D_{nom} = 1/4"$ (6 mm)				LATERAL ³⁾						
				STEEL-TO-WOOD ⁴⁾		$t_{s,w}$	WOOD-TO-WOOD ⁵⁾		WOOD-TO-WOOD ⁵⁾	
L		L_{thread}		Z_{\perp}			Z_{\parallel}	$Z_{\perp,m}$		
				SG _{NDS} 0.42	SG _{NDS} 0.50	SG _{NDS} 0.42		SG _{NDS} 0.50		
in	(mm)	in	(mm)	lbf	lbf	in	lbf	lbf	lbf	
2-3/8"	(60)	1-1/2"	(40)	225	273	-	-	-	-	
3-1/8"	(80)	2"	(50)	237	273	-	-	-	-	
4"	(100)	2-3/8"	(60)	237	273	-	-	-	-	
4-3/4"	(120)	2-3/4"	(70)	237	273	-	-	-	-	
5-1/2"	(140)	2-3/4"	(70)	237	273	-	-	-	-	
6-1/4"	(160)	2-3/4"	(70)	237	273	3-1/2"	171	201	171	
7-1/8"	(180)	2-3/4"	(70)	237	273	3-1/2"	171	201	171	
7-7/8"	(200)	2-3/4"	(70)	237	273	3-1/2"	171	201	171	
8-5/8"	(220)	2-3/4"	(70)	237	273	3-1/2"	171	201	171	
9-1/2"	(240)	2-3/4"	(70)	237	273	3-1/2"	171	201	171	
10-1/4"	(260)	2-3/4"	(70)	237	273	3-1/2"	171	201	171	
11"	(280)	2-3/4"	(70)	237	273	3-1/2"	171	201	171	
11-3/4"	(300)	2-3/4"	(70)	237	273	3-1/2"	171	201	171	

¹⁾ Minimum specified bending yield strength, determined in acc. with ASTM F1575 using D_r .
²⁾ For axial capacity determine the minimum of the corresponding adjusted values, $\min\{W_H, N\}$; in case of $\alpha < 90^\circ$ apply factor R_α .
³⁾ reference lateral design values for single shear connection with loading parallel to grain (dowel bearing strength $F_{e\parallel}$) and perpendicular to grain ($F_{e\perp}$), determined with D_r .
⁴⁾ Assumed steel plate thickness $t_{s,s} = 0.236$ in; the steel plate has to be verified separately

and according to corresponding steel standards.
⁵⁾ Values for threaded length completely located in lower component and equal specific gravity of both members.
 Typos and printing errors reserved. The values stated in combination with geometric requirements, instruction and all further notes are meant to serve as planning guides; projects should only be undertaken by authorised designers and professionals.

5/16" RAPID® partial thread washer head

T-drive (T40), washer head, friction part, HiLo thread, ridged core, YellWin 500+ coating



D_{nom}	D	D_H	D_r	D_s	N_a	N_u	$F_{yb,spec}^{1)}$
in (mm)	in	in	in	in	lbf	lbf	psi
5/16" (8)	0.315	0.787	0.210	0.232	2,100	3,160	142,000

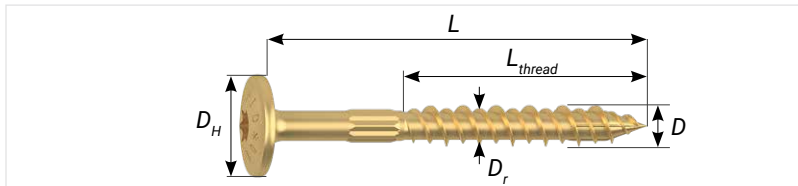

	$L_{emb,w}$	W_{90}	W_H
	in	lbf/in	lbf
SG _{NDS} 0.42	≥ 1.18	107	351
	≥ 3.98	162	
SG _{NDS} 0.50	≥ 1.06	164	370
	≥ 3.94	198	
LVL of DFir* SG _{eg} = 0.50	≥ 1.06	141	388
	≥ 3.94	199	

* acc. to ESR-1040

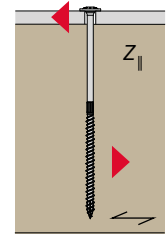
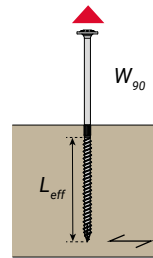
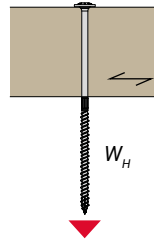
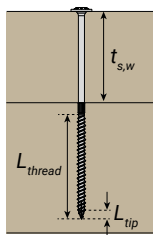

$D_{nom} = 5/16"$ (8 mm)					AXIAL ^{2) 5)}						LATERAL ³⁾	
					HEAD PULL THROUGH			WITHDRAWAL			STEEL-TO-WOOD ⁴⁾	
L		L_{thread}		$L_{thread} = L_{eff}$	W_H			W_{90}			Z_I	
					SG _{NDS} 0.42	SG _{NDS} 0.50	LVL of DFir* SG _{eg} = 0.50	SG _{NDS} 0.42	SG _{NDS} 0.50	LVL of DFir* SG _{eg} = 0.50	SG _{NDS} 0.42	SG _{NDS} 0.50
in	(mm)	in	(mm)	in	lbf	lbf	lbf	lbf	lbf	lbf	lbf	lbf
3-1/8"	(80)	2"	(50)	1.97	351	370	388	211	323	278	282	324
4"	(100)	2-3/8"	(60)	2.36	351	370	388	253	387	333	282	324
4-3/4"	(120)	3-1/8"	(80)	3.15	351	370	388	337	517	444	282	324
5-1/2"	(140)	3-1/8"	(80)	3.15	351	370	388	337	517	444	282	324
6-1/4"	(160)	3-1/8"	(80)	3.15	351	370	388	337	517	444	282	324
7-1/8"	(180)	4"	(100)	3.98	351	370	388	645	788	792	282	324
7-7/8"	(200)	4"	(100)	3.98	351	370	388	645	788	792	282	324
8-5/8"	(220)	4"	(100)	3.98	351	370	388	645	788	792	282	324
9-1/2"	(240)	4"	(100)	3.98	351	370	388	645	788	792	282	324
10-1/4"	(260)	4"	(100)	3.98	351	370	388	645	788	792	282	324
11"	(280)	4"	(100)	3.98	351	370	388	645	788	792	282	324
11-3/4"	(300)	4"	(100)	3.98	351	370	388	645	788	792	282	324
12-5/8"	(320)	4"	(100)	3.98	351	370	388	645	788	792	282	324
13-3/8"	(340)	4"	(100)	3.98	351	370	388	645	788	792	282	324
14-1/8"	(360)	4"	(100)	3.98	351	370	388	645	788	792	282	324
15"	(380)	4"	(100)	3.98	351	370	388	645	788	792	282	324
15-3/4"	(400)	4"	(100)	3.98	351	370	388	645	788	792	282	324
17-3/4"	(450)	4"	(100)	3.98	351	370	388	645	788	792	282	324
19-5/8"	(500)	4"	(100)	3.98	351	370	388	645	788	792	282	324

¹⁾ Minimum specified bending yield strength, determined in acc. with ASTM F1575 using D_r .
²⁾ For axial capacity determine the minimum of the corresponding adjusted values, $\min\{W_H, N\}$; in case of $\alpha < 90^\circ$ apply factor R_α .
³⁾ reference lateral design values for single shear connection with loading parallel to grain (dowel bearing strength F_{e1}) and perpendicular to grain (F_{e2}), determined with D_r .
⁴⁾ Assumed steel plate thickness $t_{s,s} = 0.236$ in; the steel plate has to be verified separately

and according to corresponding steel standards.
⁵⁾ Values for threaded length completely located in lower component and equal specific gravity of both members.
 Typos and printing errors reserved. The values stated in combination with geometric requirements, instruction and all further notes are meant to serve as planning guides; projects should only be undertaken by authorised designers and professionals.

5/16" RAPID® partial thread washer head

T-drive (T40), washer head, friction part, HiLo thread, ridged core, YellWin 500+ coating



D_{nom}	D	D_H	D_r	D_s	N_a	N_u	$F_{yb,spec}^{1)}$
in (mm)	in	in	in	in	lbf	lbf	psi
5/16" (8)	0.315	0.787	0.210	0.232	2,100	3,160	142,000

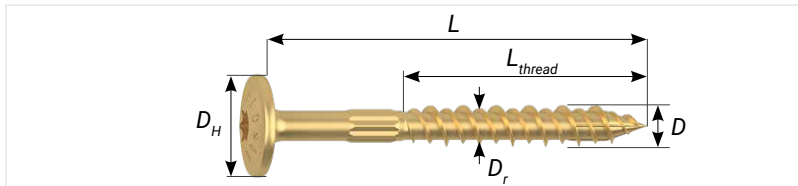

	$L_{emb,w}$	W_{g0}	W_H
	in	lbf/in	lbf
SG _{NDS} 0.42	≥ 1.18	107	351
	≥ 3.98	162	
SG _{NDS} 0.50	≥ 1.06	164	370
	≥ 3.94	198	
LVL of DFir* SG _{eg} = 0.50	≥ 1.06	141	388
	≥ 3.94	199	

* acc. to ESR-1040

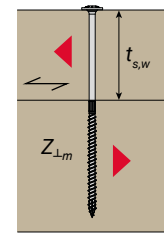
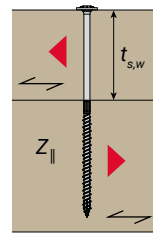
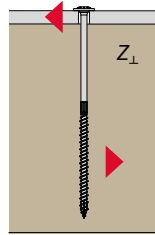
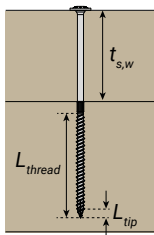

$D_{nom} = 5/16"$ (8 mm)				LATERAL ³⁾							
				STEEL-TO-WOOD ⁴⁾				WOOD-TO-WOOD ⁵⁾			
L		L_{thread}		Z_{\perp}		$t_{s,w}$	Z_{\parallel}		$Z_{\perp,m}$		
				SG _{NDS} 0.42	SG _{NDS} 0.50		SG _{NDS} 0.42	SG _{NDS} 0.50	SG _{NDS} 0.42	SG _{NDS} 0.50	
in	(mm)	in	(mm)	lbf	lbf	in	lbf	lbf	lbf	lbf	
3-1/8"	(80)	2"	(50)	225	259	-	-	-	-	-	
4"	(100)	2-3/8"	(60)	225	259	-	-	-	-	-	
4-3/4"	(120)	3-1/8"	(80)	225	259	-	-	-	-	-	
5-1/2"	(140)	3-1/8"	(80)	225	259	-	-	-	-	-	
6-1/4"	(160)	3-1/8"	(80)	225	259	-	-	-	-	-	
7-1/8"	(180)	4"	(100)	225	259	-	-	-	-	-	
7-7/8"	(200)	4"	(100)	225	259	3-1/2"	214	251	171	201	
8-5/8"	(220)	4"	(100)	225	259	3-1/2"	214	251	171	201	
9-1/2"	(240)	4"	(100)	225	259	3-1/2"	214	251	171	201	
10-1/4"	(260)	4"	(100)	225	259	3-1/2"	214	251	171	201	
11"	(280)	4"	(100)	225	259	3-1/2"	214	251	171	201	
11-3/4"	(300)	4"	(100)	225	259	3-1/2"	214	251	171	201	
12-5/8"	(320)	4"	(100)	225	259	3-1/2"	214	251	171	201	
13-3/8"	(340)	4"	(100)	225	259	3-1/2"	214	251	171	201	
14-1/8"	(360)	4"	(100)	225	259	3-1/2"	214	251	171	201	
15"	(380)	4"	(100)	225	259	3-1/2"	214	251	171	201	
15-3/4"	(400)	4"	(100)	225	259	3-1/2"	214	251	171	201	
17-3/4"	(450)	4"	(100)	225	259	3-1/2"	214	251	171	201	
19-5/8"	(500)	4"	(100)	225	259	3-1/2"	214	251	171	201	

¹⁾ Minimum specified bending yield strength, determined in acc. with ASTM F1575 using D_r .
²⁾ For axial capacity determine the minimum of the corresponding adjusted values, $\min\{W_H, N\}$; in case of $\alpha < 90^\circ$ apply factor R_{α} .
³⁾ reference lateral design values for single shear connection with loading parallel to grain (dowel bearing strength $F_{e\parallel}$) and perpendicular to grain ($F_{e\perp}$), determined with D_r .
⁴⁾ Assumed steel plate thickness $t_{s,s} = 0.236$ in; the steel plate has to be verified separately

and according to corresponding steel standards.
⁵⁾ Values for threaded length completely located in lower component and equal specific gravity of both members.
 Typos and printing errors reserved. The values stated in combination with geometric requirements, instruction and all further notes are meant to serve as planning guides; projects should only be undertaken by authorised designers and professionals.

3/8" RAPID® partial thread washer head

T-drive (T50), washer head, friction part, HiLo thread, ridged core, YellWin 500+ coating



D_{nom}	D	D_H	D_r	D_s	N_a	N_u	$F_{yb,spec}^{1)}$
in (mm)	in	in	in	in	lbf	lbf	psi
3/8" (10)	0.394	0.984	0.244	0.280	3,540	5,310	174,300

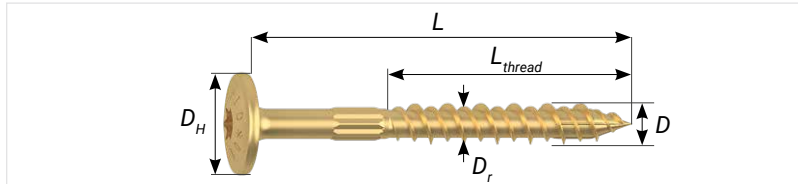

	$L_{emb,w}$	W_{90}	W_H
	in	lbf/in	lbf
SG _{NDS} 0.42	≥ 1.97	147	557
	≥ 3.98	180	
SG _{NDS} 0.50	≥ 1.77	213	696
	≥ 3.74	249	
LVL of DFir* SG _{eg} = 0.50	≥ 1.97	181	601
	≥ 3.74	212	

* acc. to ESR-1040

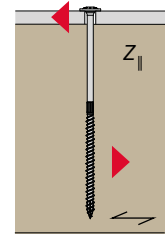
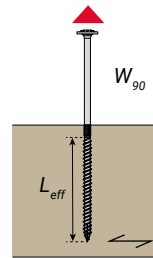
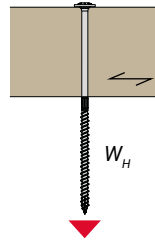
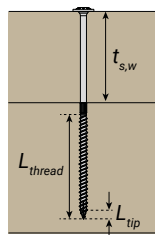

$D_{nom} = 3/8"$ (10 mm)					AXIAL ^{2) 5)}						LATERAL ³⁾	
					HEAD PULL THROUGH			WITHDRAWAL			STEEL-TO-WOOD ⁴⁾	
L		L_{thread}		$L_{thread} = L_{eff}$	W_H			W_{90}			$Z_{ }$	
					SG _{NDS} 0.42	SG _{NDS} 0.50	LVL of DFir* SG _{eg} = 0.50	SG _{NDS} 0.42	SG _{NDS} 0.50	LVL of DFir* SG _{eg} = 0.50	SG _{NDS} 0.42	SG _{NDS} 0.50
in	(mm)	in	(mm)	in	lbf	lbf	lbf	lbf	lbf	lbf	lbf	lbf
4"	(100)	2-3/8"	(60)	2.36	557	696	601	347	503	427	335	386
4-3/4"	(120)	3-1/8"	(80)	3.15	557	696	601	463	671	570	335	386
5-1/2"	(140)	3-1/8"	(80)	3.15	557	696	601	463	671	570	335	386
6-1/4"	(160)	3-1/8"	(80)	3.15	557	696	601	463	671	570	335	386
7-1/8"	(180)	4"	(100)	3.98	557	696	601	716	991	844	335	386
7-7/8"	(200)	4"	(100)	3.98	557	696	601	716	991	844	335	386
8-5/8"	(220)	4"	(100)	3.98	557	696	601	716	991	844	335	386
9-1/2"	(240)	4"	(100)	3.98	557	696	601	716	991	844	335	386
10-1/4"	(260)	4"	(100)	3.98	557	696	601	716	991	844	335	386
11"	(280)	4"	(100)	3.98	557	696	601	716	991	844	335	386
11-3/4"	(300)	4"	(100)	3.98	557	696	601	716	991	844	335	386
12-5/8"	(320)	4"	(100)	3.98	557	696	601	716	991	844	335	386
13-3/8"	(340)	4"	(100)	3.98	557	696	601	716	991	844	335	386
14-1/8"	(360)	4"	(100)	3.98	557	696	601	716	991	844	335	386
15"	(380)	4"	(100)	3.98	557	696	601	716	991	844	335	386
15-3/4"	(400)	4"	(100)	3.98	557	696	601	716	991	844	335	386
17-3/4"	(450)	4"	(100)	3.98	557	696	601	716	991	844	335	386
19-5/8"	(500)	4"	(100)	3.98	557	696	601	716	991	844	335	386

¹⁾ Minimum specified bending yield strength, determined in acc. with ASTM F1575 using D_r .
²⁾ For axial capacity determine the minimum of the corresponding adjusted values, $\min\{W_H, N\}$; in case of $\alpha < 90^\circ$ apply factor R_α .
³⁾ reference lateral design values for single shear connection with loading parallel to grain (dowel bearing strength F_{e1}) and perpendicular to grain (F_{e2}), determined with D_r .
⁴⁾ Assumed steel plate thickness $t_{s,s} = 0.236$ in; the steel plate has to be verified separately

and according to corresponding steel standards.
⁵⁾ Values for threaded length completely located in lower component and equal specific gravity of both members.
 Typos and printing errors reserved. The values stated in combination with geometric requirements, instruction and all further notes are meant to serve as planning guides; projects should only be undertaken by authorised designers and professionals.

3/8" RAPID® partial thread washer head

T-drive (T50), washer head, friction part, HiLo thread, ridged core, YellWin 500+ coating



D_{nom}	D	D_H	D_r	D_s	N_a	N_u	$F_{yb,spec}^{1)}$
in (mm)	in	in	in	in	lbf	lbf	psi
3/8" (10)	0.394	0.984	0.244	0.280	3,540	5,310	174,300

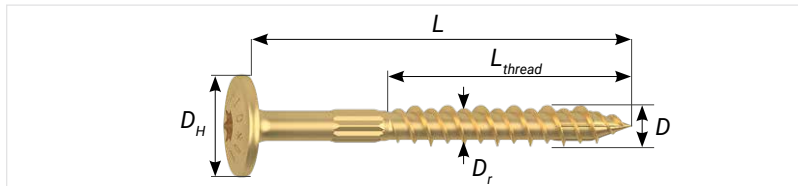

	$L_{emb,w}$	W_{90}	W_H
	in	lbf/in	lbf
SG _{NDS} 0.42	≥ 1.97	147	557
	≥ 3.98	180	
SG _{NDS} 0.50	≥ 1.77	213	696
	≥ 3.74	249	
LVL of DFir* SG _{eg} = 0.50	≥ 1.97	181	601
	≥ 3.74	212	

* acc. to ESR-1040

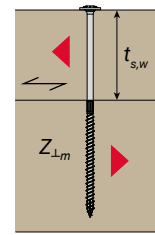
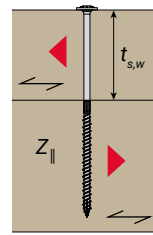
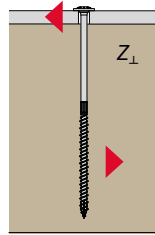
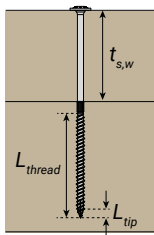

$D_{nom} = 3/8"$ (10 mm)				LATERAL ³⁾						
				STEEL-TO-WOOD ⁴⁾			WOOD-TO-WOOD ⁵⁾		WOOD-TO-WOOD ⁵⁾	
L		L_{thread}		Z_{\perp}		$t_{s,w}$	Z_{\parallel}		$Z_{\perp,m}$	
				SG _{NDS} 0.42	SG _{NDS} 0.50		SG _{NDS} 0.42	SG _{NDS} 0.50	SG _{NDS} 0.42	SG _{NDS} 0.50
in	(mm)	in	(mm)	lbf	lbf	in	lbf	lbf	lbf	lbf
4"	(100)	2-3/8"	(60)	268	309	-	-	-	-	-
4-3/4"	(120)	3-1/8"	(80)	268	309	-	-	-	-	-
5-1/2"	(140)	3-1/8"	(80)	268	309	-	-	-	-	-
6-1/4"	(160)	3-1/8"	(80)	268	309	-	-	-	-	-
7-1/8"	(180)	4"	(100)	268	309	-	-	-	-	-
7-7/8"	(200)	4"	(100)	268	309	3-1/2"	283	332	226	266
8-5/8"	(220)	4"	(100)	268	309	3-1/2"	283	332	226	266
9-1/2"	(240)	4"	(100)	268	309	3-1/2"	283	332	226	266
10-1/4"	(260)	4"	(100)	268	309	3-1/2"	283	332	226	266
11"	(280)	4"	(100)	268	309	3-1/2"	283	332	226	266
11-3/4"	(300)	4"	(100)	268	309	3-1/2"	283	332	226	266
12-5/8"	(320)	4"	(100)	268	309	3-1/2"	283	332	226	266
13-3/8"	(340)	4"	(100)	268	309	3-1/2"	283	332	226	266
14-1/8"	(360)	4"	(100)	268	309	3-1/2"	283	332	226	266
15"	(380)	4"	(100)	268	309	3-1/2"	283	332	226	266
15-3/4"	(400)	4"	(100)	268	309	3-1/2"	283	332	226	266
17-3/4"	(450)	4"	(100)	268	309	3-1/2"	283	332	226	266
19-5/8"	(500)	4"	(100)	268	309	3-1/2"	283	332	226	266

¹⁾ Minimum specified bending yield strength, determined in acc. with ASTM F1575 using D_r .
²⁾ For axial capacity determine the minimum of the corresponding adjusted values, $\min\{W_H, N\}$; in case of $\alpha < 90^\circ$ apply factor R_{α} .
³⁾ reference lateral design values for single shear connection with loading parallel to grain (dowel bearing strength $F_{e\parallel}$) and perpendicular to grain ($F_{e\perp}$), determined with D_r .
⁴⁾ Assumed steel plate thickness $t_{s,s} = 0.236$ in; the steel plate has to be verified separately

and according to corresponding steel standards.
⁵⁾ Values for threaded length completely located in lower component and equal specific gravity of both members.
 Typos and printing errors reserved. The values stated in combination with geometric requirements, instruction and all further notes are meant to serve as planning guides; projects should only be undertaken by authorised designers and professionals.

1/4" RAPID® partial thread SuperSenkFix

T-drive (T30), SuperSenkFix head, shoulder, friction part, HiLo thread, ridged core, BlueWin 700+ coating



D_{nom}	D	D_H	D_r	D_s	N_a	N_u	$F_{yb,spec}^{1)}$
in (mm)	in	in	in	in	lbf	lbf	psi
1/4" (6)	0.236	0.512	0.157	0.169	1,270	1,900	208,700

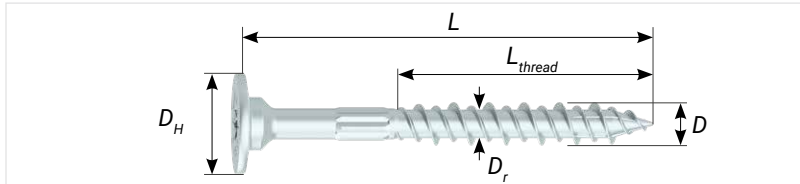

	$L_{emb,w}$	W_{90}	W_H
	in	lbf/in	lbf
SG _{NDS} 0.42	≥ 1.57	112	174
	≥ 2.75	125	
SG _{NDS} 0.50	≥ 1.57	148	-
	≥ 2.76	159	
LVL of DFir* SG _{eg} = 0.50	≥ 1.57	136	224
	≥ 2.76	167	

* acc. to ESR-1040

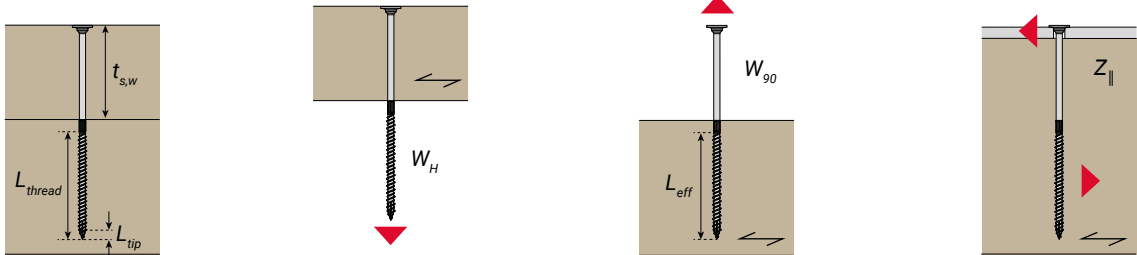

$D_{nom} = 1/4"$ (6 mm)					AXIAL ^{2) 5)}					LATERAL ³⁾	
					HEAD PULL THROUGH		WITHDRAWAL			STEEL-TO-WOOD ⁴⁾	
L		L_{thread}		$L_{thread} = L_{eff}$	W_H		W_{90}			$Z_{ }$	
					SG _{NDS} 0.42	LVL of DFir* SG _{eg} = 0.50	SG _{NDS} 0.42	SG _{NDS} 0.50	LVL of DFir* SG _{eg} = 0.50	SG _{NDS} 0.42	SG _{NDS} 0.50
in	(mm)	in	(mm)	in	lbf	lbf	lbf	lbf	lbf	lbf	lbf
3-1/8"	(80)	2"	(50)	1.97	174	224	221	292	268	237	273
4"	(100)	2-3/8"	(60)	2.36	174	224	264	349	321	237	273
4-3/4"	(120)	2-3/4"	(70)	2.76	174	224	345	439	461	237	273
5-1/2"	(140)	2-3/4"	(70)	2.76	174	224	345	439	461	237	273
6-1/4"	(160)	2-3/4"	(70)	2.76	174	224	345	439	461	237	273
7-1/8"	(180)	2-3/4"	(70)	2.76	174	224	345	439	461	237	273
7-7/8"	(200)	2-3/4"	(70)	2.76	174	224	345	439	461	237	273

¹⁾ Minimum specified bending yield strength, determined in acc. with ASTM F1575 using D_r .
²⁾ For axial capacity determine the minimum of the corresponding adjusted values, $\min\{W_H, N\}$; in case of $\alpha < 90^\circ$ apply factor R_α .
³⁾ reference lateral design values for single shear connection with loading parallel to grain (dowel bearing strength $F_{e||}$) and perpendicular to grain ($F_{e\perp}$), determined with D_r .
⁴⁾ Assumed steel plate thickness $t_{s,s} = 0.236$ in; the steel plate has to be verified separately

and according to corresponding steel standards.
⁵⁾ Values for threaded length completely located in lower component and equal specific gravity of both members.
 Typos and printing errors reserved. The values stated in combination with geometric requirements, instruction and all further notes are meant to serve as planning guides; projects should only be undertaken by authorised designers and professionals.

1/4" RAPID® partial thread SuperSenkFix

T-drive (T30), SuperSenkFix head, shoulder, friction part, HiLo thread, ridged core, BlueWin 700+ coating



D_{nom}	D	D_H	D_r	D_s	N_a	N_u	$F_{yb,spec}^{1)}$
in (mm)	in	in	in	in	lbf	lbf	psi
1/4" (6)	0.236	0.512	0.157	0.169	1,270	1,900	208,700

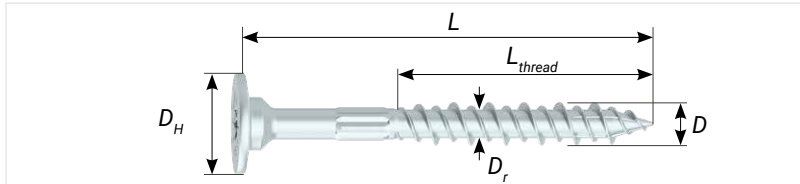

	$L_{emb,w}$	W_{90}	W_H
	in	lbf/in	lbf
SG _{NDS} 0.42	≥ 1.57	112	174
	≥ 2.75	125	
SG _{NDS} 0.50	≥ 1.57	148	-
	≥ 2.76	159	
LVL of DFir* SG _{eg} = 0.50	≥ 1.57	136	224
	≥ 2.76	167	

* acc. to ESR-1040

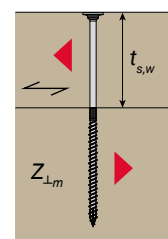
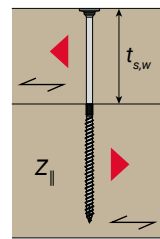
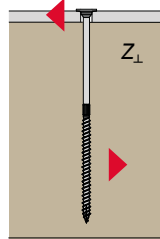
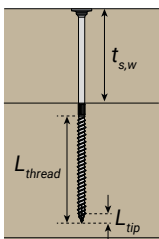

$D_{nom} = 1/4"$ (6 mm)				LATERAL ³⁾						
				STEEL-TO-WOOD ⁴⁾		$t_{s,w}$	WOOD-TO-WOOD ⁵⁾		WOOD-TO-WOOD ⁵⁾	
L		L_{thread}		Z_{\perp}			$t_{s,w}$	Z_{\parallel}		$Z_{\perp,m}$
				SG _{NDS} 0.42	SG _{NDS} 0.50	SG _{NDS} 0.42		SG _{NDS} 0.50	SG _{NDS} 0.42	SG _{NDS} 0.50
in	(mm)	in	(mm)	lbf	lbf	in	lbf	lbf	lbf	lbf
3-1/8"	(80)	2"	(50)	237	273	-	-	-	-	-
4"	(100)	2-3/8"	(60)	237	273	-	-	-	-	-
4-3/4"	(120)	2-3/4"	(70)	237	273	-	-	-	-	-
5-1/2"	(140)	2-3/4"	(70)	237	273	-	-	-	-	-
6-1/4"	(160)	2-3/4"	(70)	237	273	3-1/2"	171	201	171	201
7-1/8"	(180)	2-3/4"	(70)	237	273	3-1/2"	171	201	171	201
7-7/8"	(200)	2-3/4"	(70)	237	273	3-1/2"	171	201	171	201

¹⁾ Minimum specified bending yield strength, determined in acc. with ASTM F1575 using D_r .
²⁾ For axial capacity determine the minimum of the corresponding adjusted values, $\min\{W_H, N\}$; in case of $\alpha < 90^\circ$ apply factor R_g .
³⁾ reference lateral design values for single shear connection with loading parallel to grain (dowel bearing strength $F_{e\parallel}$) and perpendicular to grain ($F_{e\perp}$), determined with D_r .
⁴⁾ Assumed steel plate thickness $t_{s,s} = 0.236$ in; the steel plate has to be verified separately

and according to corresponding steel standards.
⁵⁾ Values for threaded length completely located in lower component and equal specific gravity of both members.
 Typos and printing errors reserved. The values stated in combination with geometric requirements, instruction and all further notes are meant to serve as planning guides; projects should only be undertaken by authorised designers and professionals.

5/16" RAPID® partial thread SuperSenkFix

T-drive (T40), SuperSenkFix head, shoulder, friction part, HiLo thread, ridged core, BlueWin 700+ coating



D_{nom}	D	D_H	D_r	D_s	N_a	N_u	$F_{yb,spec}^{1)}$
in (mm)	in	in	in	in	lbf	lbf	psi
5/16" (8)	0.315	0.748	0.210	0.232	2,100	3,160	142,000

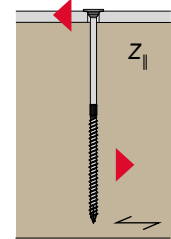
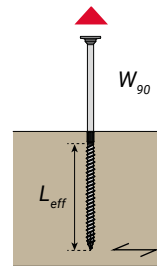
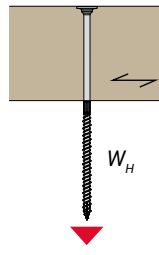
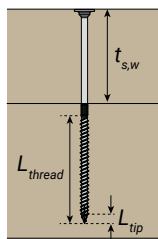
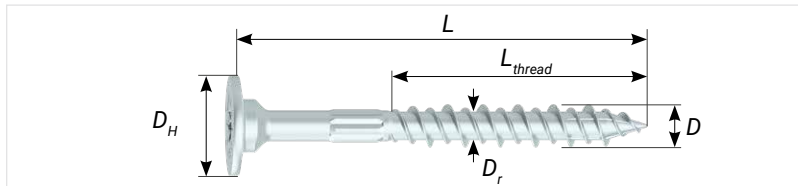

	$L_{emb,w}$	W_{90}	W_H
	in	lbf/in	lbf
SG _{NDS} 0.42	≥ 1.18	107	314
	≥ 3.98	162	
SG _{NDS} 0.50	≥ 1.06	164	-
	≥ 3.94	198	
LVL of DFir* SG _{eg} = 0.50	≥ 1.06	141	360
	≥ 3.94	199	

* acc. to ESR-1040

$D_{nom} = 5/16"$ (8 mm)					AXIAL ^{2) 5)}					LATERAL ³⁾	
					HEAD PULL THROUGH		WITHDRAWAL			STEEL-TO-WOOD ⁴⁾	
L		L_{thread}		$L_{thread} = L_{eff}$	W_H		W_{90}			$Z_{ }$	
					SG _{NDS} 0.42	LVL of DFir* SG _{eg} = 0.50	SG _{NDS} 0.42	SG _{NDS} 0.50	LVL of DFir* SG _{eg} = 0.50	SG _{NDS} 0.42	SG _{NDS} 0.50
in	(mm)	in	(mm)	in	lbf	lbf	lbf	lbf	lbf	lbf	lbf
3-1/8"	(80)	2"	(50)	1.97	314	360	211	323	278	282	324
4"	(100)	2-3/8"	(60)	2.36	314	360	253	387	333	282	324
4-3/4"	(120)	3-1/8"	(80)	3.15	314	360	337	517	444	282	324
5-1/2"	(140)	3-1/8"	(80)	3.15	314	360	337	517	444	282	324
6-1/4"	(160)	3-1/8"	(80)	3.15	314	360	337	517	444	282	324
7-1/8"	(180)	4"	(100)	3.98	314	360	645	788	792	282	324
7-7/8"	(200)	4"	(100)	3.98	314	360	645	788	792	282	324
8-5/8"	(220)	4"	(100)	3.98	314	360	645	788	792	282	324
9-1/2"	(240)	4"	(100)	3.98	314	360	645	788	792	282	324
10-1/4"	(260)	4"	(100)	3.98	314	360	645	788	792	282	324
11"	(280)	4"	(100)	3.98	314	360	645	788	792	282	324
11-3/4"	(300)	4"	(100)	3.98	314	360	645	788	792	282	324
12-5/8"	(320)	4"	(100)	3.98	314	360	645	788	792	282	324
13-3/8"	(340)	4"	(100)	3.98	314	360	645	788	792	282	324
14-1/8"	(360)	4"	(100)	3.98	314	360	645	788	792	282	324
15"	(380)	4"	(100)	3.98	314	360	645	788	792	282	324
15-3/4"	(400)	4"	(100)	3.98	314	360	645	788	792	282	324

¹⁾ Minimum specified bending yield strength, determined in acc. with ASTM F1575 using D_r .
²⁾ For axial capacity determine the minimum of the corresponding adjusted values, $\min\{W_H, N\}$; in case of $\alpha < 90^\circ$ apply factor R_α .
³⁾ reference lateral design values for single shear connection with loading parallel to grain (dowel bearing strength $F_{e||}$) and perpendicular to grain ($F_{e\perp}$), determined with D_r .
⁴⁾ Assumed steel plate thickness $t_{s,s} = 0.236$ in; the steel plate has to be verified separately

and according to corresponding steel standards.
⁵⁾ Values for threaded length completely located in lower component and equal specific gravity of both members.
 Typos and printing errors reserved. The values stated in combination with geometric requirements, instruction and all further notes are meant to serve as planning guides; projects should only be undertaken by authorised designers and professionals.

5/16" RAPID® partial thread SuperSenkFix

T-drive (T40), SuperSenkFix head, shoulder, friction part, HiLo thread, ridged core, BlueWin 700+ coating



D_{nom}	D	D_H	D_r	D_s	N_a	N_u	$F_{yb,spec}^{1)}$
in (mm)	in	in	in	in	lbf	lbf	psi
5/16" (8)	0.315	0.748	0.210	0.232	2,100	3,160	142,000

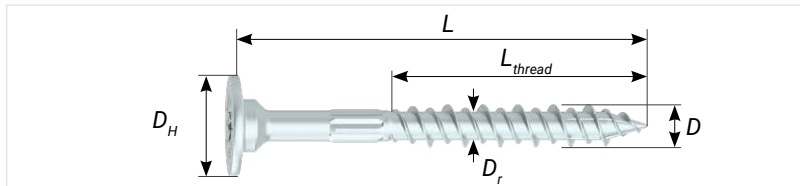

	$L_{emb,w}$	W_{90}	W_H
	in	lbf/in	lbf
SG _{NDS} 0.42	≥ 1.18	107	314
	≥ 3.98	162	
SG _{NDS} 0.50	≥ 1.06	164	-
	≥ 3.94	198	
LVL of DFir* SG _{eg} = 0.50	≥ 1.06	141	360
	≥ 3.94	199	

* acc. to ESR-1040

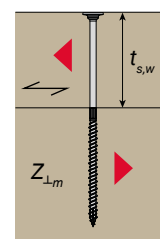
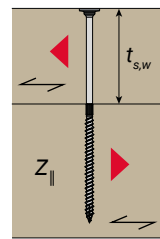
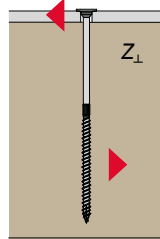
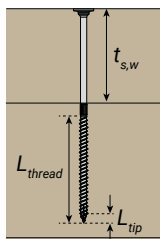

$D_{nom} = 5/16"$ (8 mm)				LATERAL ³⁾						
				STEEL-TO-WOOD ⁴⁾		$t_{s,w}$	WOOD-TO-WOOD ⁵⁾		WOOD-TO-WOOD ⁵⁾	
L		L_{thread}		Z_{\perp}			$t_{s,w}$	Z_{\parallel}		$Z_{\perp,m}$
				SG _{NDS} 0.42	SG _{NDS} 0.50	SG _{NDS} 0.42		SG _{NDS} 0.50	SG _{NDS} 0.42	SG _{NDS} 0.50
in	(mm)	in	(mm)	lbf	lbf	in	lbf	lbf	lbf	lbf
3-1/8"	(80)	2"	(50)	225	259	-	-	-	-	-
4"	(100)	2-3/8"	(60)	225	259	-	-	-	-	-
4-3/4"	(120)	3-1/8"	(80)	225	259	-	-	-	-	-
5-1/2"	(140)	3-1/8"	(80)	225	259	-	-	-	-	-
6-1/4"	(160)	3-1/8"	(80)	225	259	-	-	-	-	-
7-1/8"	(180)	4"	(100)	225	259	-	-	-	-	-
7-7/8"	(200)	4"	(100)	225	259	3-1/2"	214	251	171	201
8-5/8"	(220)	4"	(100)	225	259	3-1/2"	214	251	171	201
9-1/2"	(240)	4"	(100)	225	259	3-1/2"	214	251	171	201
10-1/4"	(260)	4"	(100)	225	259	3-1/2"	214	251	171	201
11"	(280)	4"	(100)	225	259	3-1/2"	214	251	171	201
11-3/4"	(300)	4"	(100)	225	259	3-1/2"	214	251	171	201
12-5/8"	(320)	4"	(100)	225	259	3-1/2"	214	251	171	201
13-3/8"	(340)	4"	(100)	225	259	3-1/2"	214	251	171	201
14-1/8"	(360)	4"	(100)	225	259	3-1/2"	214	251	171	201
15"	(380)	4"	(100)	225	259	3-1/2"	214	251	171	201
15-3/4"	(400)	4"	(100)	225	259	3-1/2"	214	251	171	201

¹⁾ Minimum specified bending yield strength, determined in acc. with ASTM F1575 using D_r .
²⁾ For axial capacity determine the minimum of the corresponding adjusted values, $\min\{W'_H; N\}$; in case of $\alpha < 90^\circ$ apply factor R_g ;
³⁾ reference lateral design values for single shear connection with loading parallel to grain (dowel bearing strength $F_{e\parallel}$) and perpendicular to grain ($F_{e\perp}$), determined with D_r .
⁴⁾ Assumed steel plate thickness $t_{s,s} = 0.236$ in; the steel plate has to be verified separately

and according to corresponding steel standards.
⁵⁾ Values for threaded length completely located in lower component and equal specific gravity of both members.
 Typos and printing errors reserved. The values stated in combination with geometric requirements, instruction and all further notes are meant to serve as planning guides; projects should only be undertaken by authorised designers and professionals.

3/8" RAPID® partial thread SuperSenkFix

T-drive (T50), SuperSenkFix head, shoulder, friction part, HiLo thread, ridged core, BlueWin 700+ coating



D_{nom}	D	D_H	D_r	D_s	N_a	N_u	$F_{yb,spec}^{1)}$
in (mm)	in	in	in	in	lbf	lbf	psi
3/8" (10)	0.394	0.945	0.244	0.280	3,540	5,310	174,300

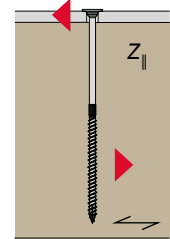
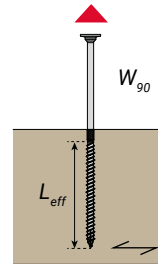
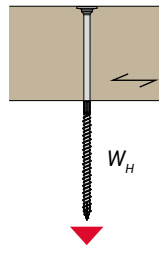
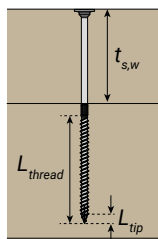
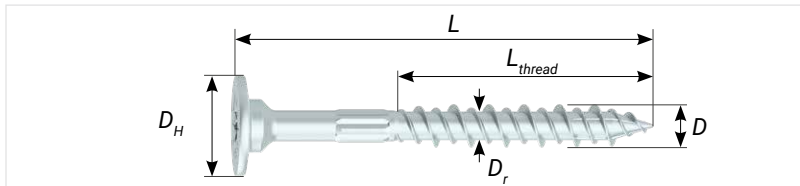

	$L_{emb,w}$	W_{90}	W_H
	in	lbf/in	lbf
SG _{NDS} 0.42	≥ 1.97	147	522
	≥ 3.98	180	
SG _{NDS} 0.50	≥ 1.77	213	-
	≥ 3.74	249	
LVL of DFir* SG _{eg} = 0.50	≥ 1.97	181	576
	≥ 3.74	212	

* acc. to ESR-1040

$D_{nom} = 3/8"$ (10 mm)					AXIAL ^{2) 5)}					LATERAL ³⁾	
					HEAD PULL THROUGH		WITHDRAWAL			STEEL-TO-WOOD ⁴⁾	
L		L_{thread}		$L_{thread} = L_{eff}$	W_H		W_{90}			$Z_{ }$	
					SG _{NDS} 0.42	LVL of DFir* SG _{eg} = 0.50	SG _{NDS} 0.42	SG _{NDS} 0.50	LVL of DFir* SG _{eg} = 0.50	SG _{NDS} 0.42	SG _{NDS} 0.50
in	(mm)	in	(mm)	in	lbf	lbf	lbf	lbf	lbf	lbf	lbf
4-3/4"	(120)	3-1/8"	(80)	3.15	522	576	463	671	570	335	386
5-1/2"	(140)	3-1/8"	(80)	3.15	522	576	463	671	570	335	386
6-1/4"	(160)	3-1/8"	(80)	3.15	522	576	463	671	570	335	386
7-1/8"	(180)	4"	(100)	3.98	522	576	716	991	844	335	386
7-7/8"	(200)	4"	(100)	3.98	522	576	716	991	844	335	386
8-5/8"	(220)	4"	(100)	3.98	522	576	716	991	844	335	386
9-1/2"	(240)	4"	(100)	3.98	522	576	716	991	844	335	386
10-1/4"	(260)	4"	(100)	3.98	522	576	716	991	844	335	386
11"	(280)	4"	(100)	3.98	522	576	716	991	844	335	386
11-3/4"	(300)	4"	(100)	3.98	522	576	716	991	844	335	386
13-3/8"	(350)	4"	(100)	3.98	522	576	716	991	844	335	386
15-3/4"	(400)	4"	(100)	3.98	522	576	716	991	844	335	386

¹⁾ Minimum specified bending yield strength, determined in acc. with ASTM F1575 using D_r .
²⁾ For axial capacity determine the minimum of the corresponding adjusted values, $\min\{W_H, N\}$; in case of $\alpha < 90^\circ$ apply factor R_α .
³⁾ reference lateral design values for single shear connection with loading parallel to grain (dowel bearing strength $F_{e||}$) and perpendicular to grain ($F_{e\perp}$), determined with D_r .
⁴⁾ Assumed steel plate thickness $t_{s,s} = 0.236$ in; the steel plate has to be verified separately

and according to corresponding steel standards.
⁵⁾ Values for threaded length completely located in lower component and equal specific gravity of both members.
 Typos and printing errors reserved. The values stated in combination with geometric requirements, instruction and all further notes are meant to serve as planning guides; projects should only be undertaken by authorised designers and professionals.

3/8" RAPID® partial thread SuperSenkFix

T-drive (T50), SuperSenkFix head, shoulder, friction part, HiLo thread, ridged core, BlueWin 700+ coating



D_{nom}	D	D_H	D_r	D_s	N_a	N_u	$F_{yb,spec}^{1)}$
in (mm)	in	in	in	in	lbf	lbf	psi
3/8" (10)	0.394	0.945	0.244	0.280	3,540	5,310	174,300

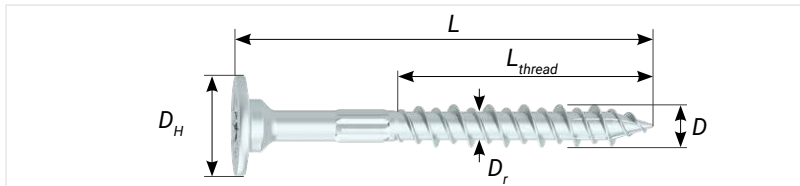

	$L_{emb,w}$	W_{90}	W_H
	in	lbf/in	lbf
$SG_{NDS} 0.42$	≥ 1.97	147	522
	≥ 3.98	180	
$SG_{NDS} 0.50$	≥ 1.77	213	-
	≥ 3.74	249	
LVL of DFir* $SG_{eg} = 0.50$	≥ 1.97	181	576
	≥ 3.74	212	

* acc. to ESR-1040

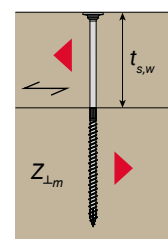
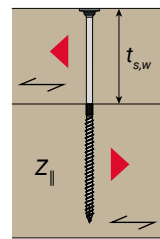
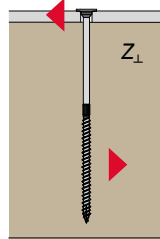
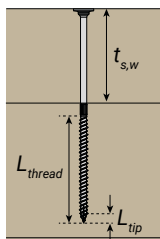

$D_{nom} = 3/8"$ (10 mm)				LATERAL ³⁾						
				STEEL-TO-WOOD ⁴⁾		$t_{s,w}$	WOOD-TO-WOOD ⁵⁾		WOOD-TO-WOOD ⁵⁾	
L		L_{thread}		Z_{\perp}			Z_{\parallel}	$Z_{\perp,m}$		
				$SG_{NDS} 0.42$	$SG_{NDS} 0.50$	$SG_{NDS} 0.42$		$SG_{NDS} 0.50$	$SG_{NDS} 0.42$	$SG_{NDS} 0.50$
in	(mm)	in	(mm)	lbf	lbf	in	lbf	lbf	lbf	lbf
4-3/4"	(120)	3-1/8"	(80)	268	309	-	-	-	-	-
5-1/2"	(140)	3-1/8"	(80)	268	309	-	-	-	-	-
6-1/4"	(160)	3-1/8"	(80)	268	309	-	-	-	-	-
7-1/8"	(180)	4"	(100)	268	309	-	-	-	-	-
7-7/8"	(200)	4"	(100)	268	309	3-1/2"	283	332	226	266
8-5/8"	(220)	4"	(100)	268	309	3-1/2"	283	332	226	266
9-1/2"	(240)	4"	(100)	268	309	3-1/2"	283	332	226	266
10-1/4"	(260)	4"	(100)	268	309	3-1/2"	283	332	226	266
11"	(280)	4"	(100)	268	309	3-1/2"	283	332	226	266
11-3/4"	(300)	4"	(100)	268	309	3-1/2"	283	332	226	266
13-3/8"	(350)	4"	(100)	268	309	3-1/2"	283	332	226	266
15-3/4"	(400)	4"	(100)	268	309	3-1/2"	283	332	226	266

¹⁾ Minimum specified bending yield strength, determined in acc. with ASTM F1575 using D_r .
²⁾ For axial capacity determine the minimum of the corresponding adjusted values, $\min\{W; W_H; N\}$; in case of $\alpha < 90^\circ$ apply factor R_α .
³⁾ reference lateral design values for single shear connection with loading parallel to grain (dowel bearing strength $F_{e\parallel}$) and perpendicular to grain ($F_{e\perp}$), determined with D_r .
⁴⁾ Assumed steel plate thickness $t_{s,s} = 0.236$ in; the steel plate has to be verified separately

and according to corresponding steel standards.
⁵⁾ Values for threaded length completely located in lower component and equal specific gravity of both members.
 Typos and printing errors reserved. The values stated in combination with geometric requirements, instruction and all further notes are meant to serve as planning guides; projects should only be undertaken by authorised designers and professionals.

5/16" RAPID® partial thread Dual

T-drive (T30) & hexagonal drive (SW12), Dual head, shoulder, friction part, HiLo thread, ridged core, BlueWin coating



D_{nom}	D	D_H	D_r	D_s	N_a	N_u	$F_{yb,spec}^{1)}$
in (mm)	in	in	in	in	lbf	lbf	psi
5/16" (8)	0.315	0.472	0.210	0.232	2,100	3,160	142,000

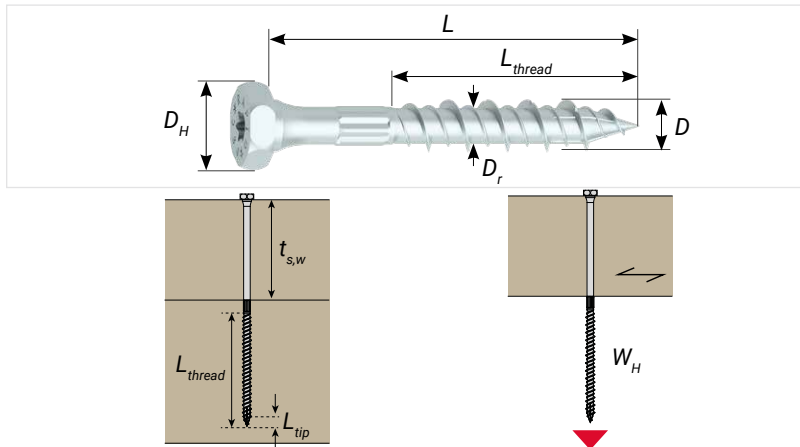

	$L_{emb,w}$	W_{90}	W_H
	in	lbf/in	lbf
SG _{NDS} 0.42	≥ 1.18	107	175
	≥ 3.98	162	
SG _{NDS} 0.50	≥ 1.06	164	-
	≥ 3.94	198	
LVL of DFir* SG _{eg} = 0.50	≥ 1.06	141	254
	≥ 3.94	199	

* acc. to ESR-1040

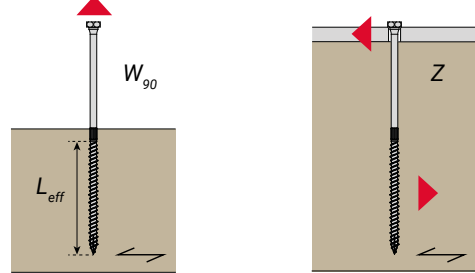

$D_{nom} = 5/16"$ (8 mm)					AXIAL ^{2) 5)}					LATERAL ³⁾	
					HEAD PULL THROUGH		WITHDRAWAL			STEEL-TO-WOOD ⁴⁾	
L		L_{thread}		$L_{thread} = L_{eff}$	W_H		W_{90}			$Z_{ }$	
					SG _{NDS} 0.42	LVL of DFir* SG _{eg} = 0.50	SG _{NDS} 0.42	SG _{NDS} 0.50	LVL of DFir* SG _{eg} = 0.50	SG _{NDS} 0.42	SG _{NDS} 0.50
in	(mm)	in	(mm)	in	lbf	lbf	lbf	lbf	lbf	lbf	lbf
2"	(50)	1-3/16"	(30)	1.18	175	254	126	194	166	224	279
2-3/8"	(60)	1-1/2"	(40)	1.57	175	254	168	257	221	253	323
2-3/4"	(70)	1-1/2"	(40)	1.57	175	254	168	257	221	282	324
3-1/8"	(80)	2"	(50)	1.97	175	254	211	323	278	282	324
4"	(100)	2-3/8"	(60)	2.36	175	254	253	387	333	282	324
4-3/4"	(120)	3-1/8"	(80)	3.15	175	254	337	517	444	282	324
5-1/2"	(140)	3-1/8"	(80)	3.15	175	254	337	517	444	282	324
6-1/4"	(160)	3-1/8"	(80)	3.15	175	254	337	517	444	282	324
7-1/8"	(180)	4"	(100)	3.98	175	254	645	788	792	282	324
7-7/8"	(200)	4"	(100)	3.98	175	254	645	788	792	282	324
8-5/8"	(220)	4"	(100)	3.98	175	254	645	788	792	282	324
9-1/2"	(240)	4"	(100)	3.98	175	254	645	788	792	282	324
10-1/4"	(260)	4"	(100)	3.98	175	254	645	788	792	282	324
11"	(280)	4"	(100)	3.98	175	254	645	788	792	282	324
11-3/4"	(300)	4"	(100)	3.98	175	254	645	788	792	282	324
12-5/8"	(320)	4"	(100)	3.98	175	254	645	788	792	282	324
13-3/8"	(340)	4"	(100)	3.98	175	254	645	788	792	282	324
14-1/8"	(360)	4"	(100)	3.98	175	254	645	788	792	282	324
15"	(380)	4"	(100)	3.98	175	254	645	788	792	282	324
15-3/4"	(400)	4"	(100)	3.98	175	254	645	788	792	282	324

¹⁾ Minimum specified bending yield strength, determined in acc. with ASTM F1575 using D_r .
²⁾ For axial capacity determine the minimum of the corresponding adjusted values, $\min\{W_H, N\}$; in case of $\alpha < 90^\circ$ apply factor R_α .
³⁾ reference lateral design values for single shear connection with loading parallel to grain (dowel bearing strength F_{e1}) and perpendicular to grain (F_{e2}), determined with D_r .
⁴⁾ Assumed steel plate thickness $t_{s,s} = 0.236$ in; the steel plate has to be verified separately

and according to corresponding steel standards.
⁵⁾ Values for threaded length completely located in lower component and equal specific gravity of both members.
 Typos and printing errors reserved. The values stated in combination with geometric requirements, instruction and all further notes are meant to serve as planning guides; projects should only be undertaken by authorised designers and professionals.

5/16" RAPID® partial thread Dual

T-drive (T30) & hexagonal drive (SW12), Dual head, shoulder, friction part, HiLo thread, ridged core, BlueWin coating



D_{nom}	D	D_H	D_r	D_s	N_a	N_u	$F_{y,spec}^{1)}$
in (mm)	in	in	in	in	lbf	lbf	psi
5/16" (8)	0.315	0.472	0.210	0.232	2,100	3,160	142,000

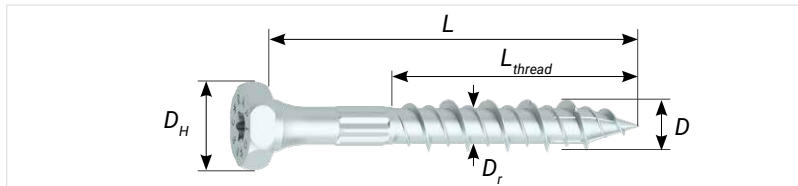

	$L_{emb,w}$	W_{90}	W_H
	in	lbf/in	lbf
$SG_{NDS} 0.42$	≥ 1.18	107	175
	≥ 3.98	162	
$SG_{NDS} 0.50$	≥ 1.06	164	-
	≥ 3.94	198	
LVL of DFir* $SG_{eg} = 0.50$	≥ 1.06	141	254
	≥ 3.94	199	

* acc. to ESR-1040

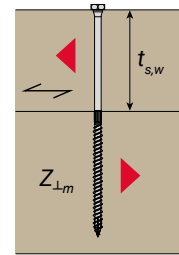
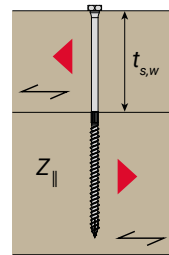
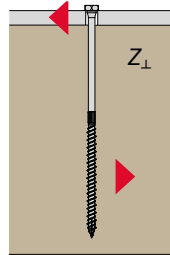
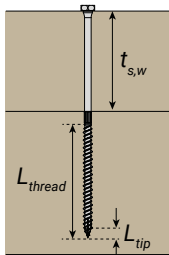

$D_{nom} = 5/16"$ (8 mm)				LATERAL ³⁾						
				STEEL-TO-WOOD ⁴⁾		$t_{s,w}$	WOOD-TO-WOOD ⁵⁾		WOOD-TO-WOOD ⁵⁾	
L		L_{thread}		Z_{\perp}			Z_{\parallel}	$Z_{\perp,m}$		
				$SG_{NDS} 0.42$	$SG_{NDS} 0.50$	$SG_{NDS} 0.42$		$SG_{NDS} 0.50$	$SG_{NDS} 0.42$	$SG_{NDS} 0.50$
in	(mm)	in	(mm)	lbf	lbf	in	lbf	lbf	lbf	
2"	(50)	1-3/16"	(30)	180	223	-	-	-	-	
2-3/8"	(60)	1-1/2"	(40)	202	258	-	-	-	-	
2-3/4"	(70)	1-1/2"	(40)	225	259	-	-	-	-	
3-1/8"	(80)	2"	(50)	225	259	-	-	-	-	
4"	(100)	2-3/8"	(60)	225	259	-	-	-	-	
4-3/4"	(120)	3-1/8"	(80)	225	259	-	-	-	-	
5-1/2"	(140)	3-1/8"	(80)	225	259	-	-	-	-	
6-1/4"	(160)	3-1/8"	(80)	225	259	-	-	-	-	
7-1/8"	(180)	4"	(100)	225	259	-	-	-	-	
7-7/8"	(200)	4"	(100)	225	259	3-1/2"	214	251	171 201	
8-5/8"	(220)	4"	(100)	225	259	3-1/2"	214	251	171 201	
9-1/2"	(240)	4"	(100)	225	259	3-1/2"	214	251	171 201	
10-1/4"	(260)	4"	(100)	225	259	3-1/2"	214	251	171 201	
11"	(280)	4"	(100)	225	259	3-1/2"	214	251	171 201	
11-3/4"	(300)	4"	(100)	225	259	3-1/2"	214	251	171 201	
12-5/8"	(320)	4"	(100)	225	259	3-1/2"	214	251	171 201	
13-3/8"	(340)	4"	(100)	225	259	3-1/2"	214	251	171 201	
14-1/8"	(360)	4"	(100)	225	259	3-1/2"	214	251	171 201	
15"	(380)	4"	(100)	225	259	3-1/2"	214	251	171 201	
15-3/4"	(400)	4"	(100)	225	259	3-1/2"	214	251	171 201	

¹⁾ Minimum specified bending yield strength, determined in acc. with ASTM F1575 using D_r .
²⁾ For axial capacity determine the minimum of the corresponding adjusted values, $\min\{W_t; W_s; N\}$; in case of $\alpha < 90^\circ$ apply factor R_{α} .
³⁾ reference lateral design values for single shear connection with loading parallel to grain (dowel bearing strength $F_{e\parallel}$) and perpendicular to grain ($F_{e\perp}$), determined with D_r .
⁴⁾ Assumed steel plate thickness $t_{s,s} = 0.236$ in; the steel plate has to be verified separately

and according to corresponding steel standards.
⁵⁾ Values for threaded length completely located in lower component and equal specific gravity of both members.
 Typos and printing errors reserved. The values stated in combination with geometric requirements, instruction and all further notes are meant to serve as planning guides; projects should only be undertaken by authorised designers and professionals.

3/8" RAPID® partial thread Dual

T-drive (T40) & hexagonal drive (SW15), Dual head, shoulder, friction part, HiLo thread, ridged core, BlueWin coating



D_{nom}	D	D_H	D_r	D_s	N_a	N_u	$F_{yb,spec}^{1)}$
in (mm)	in	in	in	in	lbf	lbf	psi
3/8" (10)	0.394	0.591	0.244	0.280	3,540	5,310	174,300

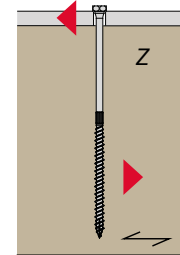
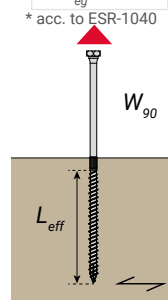
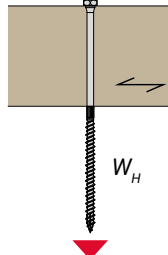
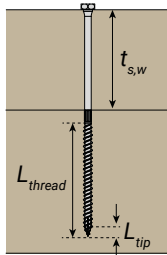
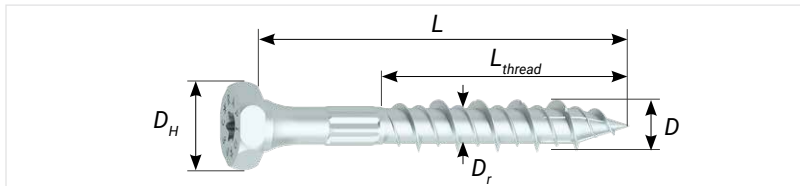

	$L_{emb,w}$	W_{90}	W_H
	in	lbf/in	lbf
SG _{NDS} 0.42	≥ 1.97	147	266
	≥ 3.98	180	
SG _{NDS} 0.50	≥ 1.77	213	-
	≥ 3.74	249	
LVL of DFir* SG _{eg} = 0.50	≥ 1.97	181	411
	≥ 3.74	212	

* acc. to ESR-1040

$D_{nom} = 3/8"$ (10 mm)					AXIAL ^{2) 5)}					LATERAL ³⁾	
					HEAD PULL THROUGH		WITHDRAWAL			STEEL-TO-WOOD ⁴⁾	
L		L_{thread}		$L_{thread} = L_{eff}$	W_H		W_{90}			$Z_{ }$	
					SG _{NDS} 0.42	LVL of DFir* SG _{eg} = 0.50	SG _{NDS} 0.42	SG _{NDS} 0.50	LVL of DFir* SG _{eg} = 0.50	SG _{NDS} 0.42	SG _{NDS} 0.50
in	(mm)	in	(mm)	in	lbf	lbf	lbf	lbf	lbf	lbf	lbf
2-3/8"	(60)	1-1/2"	(40)	1.57	266	411	-	-	-	254	322
2-3/4"	(70)	1-1/2"	(40)	1.57	266	411	-	-	-	287	372
3-1/8"	(80)	2"	(50)	1.97	266	411	290	420	357	323	386
4"	(100)	2-3/8"	(60)	2.36	266	411	347	503	427	335	386
4-3/4"	(120)	3-1/8"	(80)	3.15	266	411	463	671	570	335	386
5-1/2"	(140)	3-1/8"	(80)	3.15	266	411	463	671	570	335	386
6-1/4"	(160)	3-1/8"	(80)	3.15	266	411	463	671	570	335	386
7-1/8"	(180)	4"	(100)	3.98	266	411	716	991	844	335	386
7-7/8"	(200)	4"	(100)	3.98	266	411	716	991	844	335	386
8-5/8"	(220)	4"	(100)	3.98	266	411	716	991	844	335	386
9-1/2"	(240)	4"	(100)	3.98	266	411	716	991	844	335	386
10-1/4"	(260)	4"	(100)	3.98	266	411	716	991	844	335	386
11"	(280)	4"	(100)	3.98	266	411	716	991	844	335	386
11-3/4"	(300)	4"	(100)	3.98	266	411	716	991	844	335	386
13-3/8"	(350)	4"	(100)	3.98	266	411	716	991	844	335	386
15-3/4"	(400)	4"	(100)	3.98	266	411	716	991	844	335	386

¹⁾ Minimum specified bending yield strength, determined in acc. with ASTM F1575 using D_r .
²⁾ For axial capacity determine the minimum of the corresponding adjusted values, $\min\{W_H, N\}$; in case of $\alpha < 90^\circ$ apply factor R_α .
³⁾ reference lateral design values for single shear connection with loading parallel to grain (dowel bearing strength $F_{e||}$) and perpendicular to grain ($F_{e\perp}$), determined with D_r .
⁴⁾ Assumed steel plate thickness $t_{s,s} = 0.236$ in; the steel plate has to be verified separately

and according to corresponding steel standards.
⁵⁾ Values for threaded length completely located in lower component and equal specific gravity of both members.
 Typos and printing errors reserved. The values stated in combination with geometric requirements, instruction and all further notes are meant to serve as planning guides; projects should only be undertaken by authorised designers and professionals.

3/8" RAPID® partial thread Dual

T-drive (T40) & hexagonal drive (SW15), Dual head, shoulder, friction part, HiLo thread, ridged core, BlueWin coating



D_{nom}	D	D_H	D_r	D_s	N_a	N_u	$F_{yb,spec}^{1)}$
in (mm)	in	in	in	in	lbf	lbf	psi
3/8" (10)	0.394	0.591	0.244	0.280	3,540	5,310	174,300

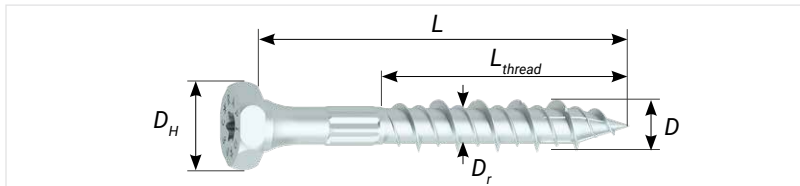

	$L_{emb,w}$	W_{90}	W_H
	in	lbf/in	lbf
SG _{NDS} 0.42	≥ 1.97	147	266
	≥ 3.98	180	
SG _{NDS} 0.50	≥ 1.77	213	-
	≥ 3.74	249	
LVL of DFir* SG _{eg} = 0.50	≥ 1.97	181	411
	≥ 3.74	212	

* acc. to ESR-1040

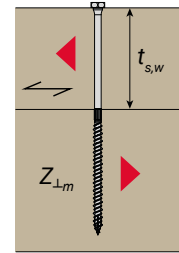
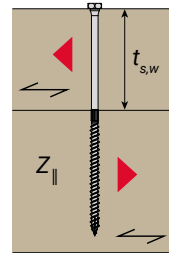
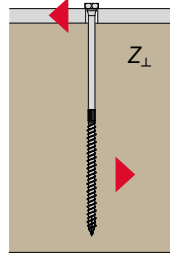
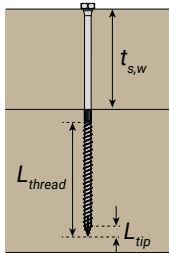

$D_{nom} = 3/8"$ (10 mm)				LATERAL ³⁾					
				STEEL-TO-WOOD ⁴⁾		$t_{s,w}$	WOOD-TO-WOOD ⁵⁾		WOOD-TO-WOOD ⁵⁾
L		L_{thread}		Z_{\perp}			Z_{\parallel}		$Z_{\perp,m}$
				SG _{NDS} 0.42	SG _{NDS} 0.50	SG _{NDS} 0.42	SG _{NDS} 0.50	SG _{NDS} 0.42	SG _{NDS} 0.50
in	(mm)	in	(mm)	lbf	lbf	in	lbf	lbf	lbf
2-3/8"	(60)	1-1/2"	(40)	203	258	-	-	-	-
2-3/4"	(70)	1-1/2"	(40)	230	298	-	-	-	-
3-1/8"	(80)	2"	(50)	259	309	-	-	-	-
4"	(100)	2-3/8"	(60)	268	309	-	-	-	-
4-3/4"	(120)	3-1/8"	(80)	268	309	-	-	-	-
5-1/2"	(140)	3-1/8"	(80)	268	309	-	-	-	-
6-1/4"	(160)	3-1/8"	(80)	268	309	-	-	-	-
7-1/8"	(180)	4"	(100)	268	309	-	-	-	-
7-7/8"	(200)	4"	(100)	268	309	3-1/2"	283	332	226
8-5/8"	(220)	4"	(100)	268	309	3-1/2"	283	332	226
9-1/2"	(240)	4"	(100)	268	309	3-1/2"	283	332	226
10-1/4"	(260)	4"	(100)	268	309	3-1/2"	283	332	226
11"	(280)	4"	(100)	268	309	3-1/2"	283	332	226
11-3/4"	(300)	4"	(100)	268	309	3-1/2"	283	332	226
13-3/8"	(350)	4"	(100)	268	309	3-1/2"	283	332	226
15-3/4"	(400)	4"	(100)	268	309	3-1/2"	283	332	226

¹⁾ Minimum specified bending yield strength, determined in acc. with ASTM F1575 using D_r .
²⁾ For axial capacity determine the minimum of the corresponding adjusted values, $\min\{W; W_H; N\}$; in case of $\alpha < 90^\circ$ apply factor R_α .
³⁾ reference lateral design values for single shear connection with loading parallel to grain (dowel bearing strength $F_{e\parallel}$) and perpendicular to grain ($F_{e\perp}$), determined with D_r .
⁴⁾ Assumed steel plate thickness $t_{s,s} = 0.236$ in; the steel plate has to be verified separately

and according to corresponding steel standards.
⁵⁾ Values for threaded length completely located in lower component and equal specific gravity of both members.
 Typos and printing errors reserved. The values stated in combination with geometric requirements, instruction and all further notes are meant to serve as planning guides; projects should only be undertaken by authorised designers and professionals.

1/2" RAPID® partial thread Dual

T-drive (T40) & hexagonal drive (SW17), Dual head, shoulder, friction part, single thread, ridged core, BlueWin coating



D_{nom}	D	D_H	D_r	D_s	N_a	N_u	$F_{yb,spec}^{1)}$
in (mm)	in	in	in	in	lbf	lbf	psi
1/2" (12)	0.472	0.669	0.268	0.323	3,900	5,820	192,900

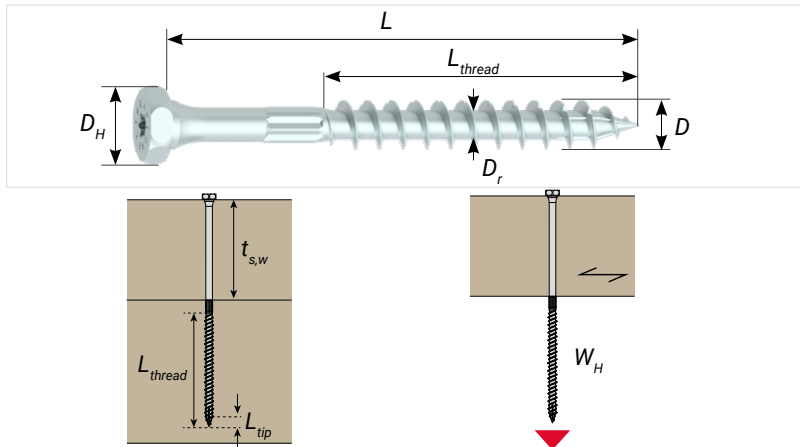

	$L_{emb,w}$	W_{90}	W_H
	in	lbf/in	lbf
SG _{NDS} 0.42	≥ 1.97	194	303
	≥ 4.72	219	
SG _{NDS} 0.50	≥ 1.97	232	-
	≥ 4.72	296	
LVL of DFir* SG _{eg} = 0.50	≥ 1.97	201	448
	≥ 4.72	249	

* acc. to ESR-1040

$D_{nom} = 1/2"$ (12 mm)					AXIAL ^{2) 5)}					LATERAL ³⁾	
					HEAD PULL THROUGH		WITHDRAWAL			STEEL-TO-WOOD ⁴⁾	
L		L_{thread}		$L_{thread} = L_{eff}$	W_H		W_{90}			$Z_{ }$	
					SG _{NDS} 0.42	LVL of DFir* SG _{eg} = 0.50	SG _{NDS} 0.42	SG _{NDS} 0.50	LVL of DFir* SG _{eg} = 0.50	SG _{NDS} 0.42	SG _{NDS} 0.50
in	(mm)	in	(mm)	in	lbf	lbf	lbf	lbf	lbf	lbf	lbf
3-1/8"	(80)	2"	(50)	1.97	303	448	382	457	396	381	444
4"	(100)	2-3/8"	(60)	2.36	303	448	458	548	474	432	467
4-3/4"	(120)	3-1/8"	(80)	3.15	303	448	611	731	633	432	467
5-1/2"	(140)	3-1/8"	(80)	3.15	303	448	611	731	633	432	467
6-1/4"	(160)	3-1/8"	(80)	3.15	303	448	611	731	633	432	467
7-1/8"	(180)	4"	(100)	3.94	303	448	764	914	792	432	467
7-7/8"	(200)	4"	(100)	3.94	303	448	764	914	792	432	467
8-5/8"	(220)	4"	(100)	3.94	303	448	764	914	792	432	467
9-1/2"	(240)	4"	(100)	3.94	303	448	764	914	792	432	467
10-1/4"	(260)	4"	(100)	3.94	303	448	764	914	792	432	467
11"	(280)	4"	(100)	3.94	303	448	764	914	792	432	467
11-3/4"	(300)	4-3/4"	(120)	4.72	303	448	1034	1397	1175	432	467
14-1/8"	(350)	4-3/4"	(120)	4.72	303	448	1034	1397	1175	432	467
15-3/4"	(400)	4-3/4"	(120)	4.72	303	448	1034	1397	1175	432	467

¹⁾ Minimum specified bending yield strength, determined in acc. with ASTM F1575 using D_r .
²⁾ For axial capacity determine the minimum of the corresponding adjusted values, $\min\{W_H, N\}$; in case of $\alpha < 90^\circ$ apply factor R_α .
³⁾ reference lateral design values for single shear connection with loading parallel to grain (dowel bearing strength $F_{e||}$) and perpendicular to grain ($F_{e\perp}$), determined with D_r .
⁴⁾ Assumed steel plate thickness $t_{s,s} = 0.236$ in; the steel plate has to be verified separately

and according to corresponding steel standards.
⁵⁾ Values for threaded length completely located in lower component and equal specific gravity of both members.
 Typos and printing errors reserved. The values stated in combination with geometric requirements, instruction and all further notes are meant to serve as planning guides; projects should only be undertaken by authorised designers and professionals.

1/2" RAPID® partial thread Dual

T-drive (T40) & hexagonal drive (SW17), Dual head, shoulder, friction part, single thread, ridged core, BlueWin coating



D_{nom}	D	D_H	D_r	D_s	N_a	N_u	$F_{yb,spec}^{1)}$
in (mm)	in	in	in	in	lbf	lbf	psi
1/2" (12)	0.472	0.669	0.268	0.323	3,900	5,820	192,900

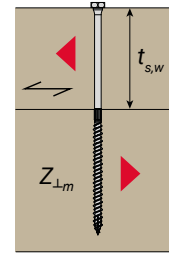
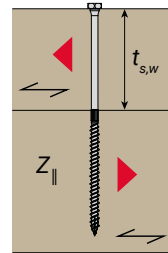
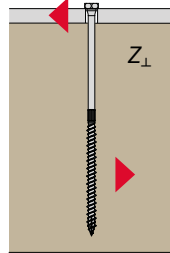
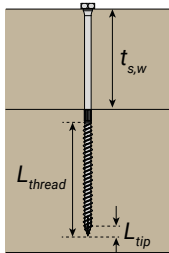
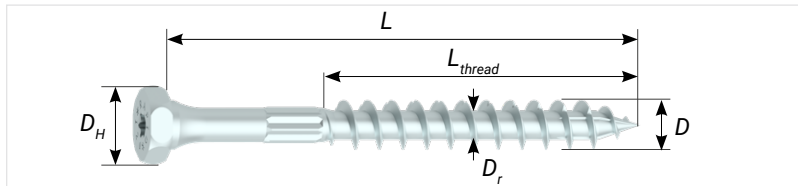

	$L_{emb,w}$	W_{90}	W_H
	in	lbf/in	lbf
SG _{NDS} 0.42	≥ 1.97	194	303
	≥ 4.72	219	
SG _{NDS} 0.50	≥ 1.97	232	-
	≥ 4.72	296	
LVL of DFir* SG _{eg} = 0.50	≥ 1.97	201	448
	≥ 4.72	249	

* acc. to ESR-1040

$D_{nom} = 1/2"$ (12 mm)				LATERAL ³⁾							
				STEEL-TO-WOOD ⁴⁾				WOOD-TO-WOOD ⁵⁾			
L		L_{thread}		Z_{\perp}		$t_{s,w}$	Z_{\parallel}		$Z_{\perp,m}$		
				SG _{NDS} 0.42	SG _{NDS} 0.50		SG _{NDS} 0.42	SG _{NDS} 0.50	SG _{NDS} 0.42	SG _{NDS} 0.50	
in	(mm)	in	(mm)	lbf	lbf	in	lbf	lbf	lbf	lbf	
3-1/8"	(80)	2"	(50)	228	283	-	-	-	-	-	
4"	(100)	2-3/8"	(60)	284	333	-	-	-	-	-	
4-3/4"	(120)	3-1/8"	(80)	297	333	-	-	-	-	-	
5-1/2"	(140)	3-1/8"	(80)	297	333	-	-	-	-	-	
6-1/4"	(160)	3-1/8"	(80)	297	333	-	-	-	-	-	
7-1/8"	(180)	4"	(100)	297	333	-	-	-	-	-	
7-7/8"	(200)	4"	(100)	297	333	3-1/2"	390	426	285	318	
8-5/8"	(220)	4"	(100)	297	333	3-1/2"	390	426	285	318	
9-1/2"	(240)	4"	(100)	297	333	3-1/2"	390	426	285	318	
10-1/4"	(260)	4"	(100)	297	333	3-1/2"	390	426	285	318	
11"	(280)	4"	(100)	297	333	3-1/2"	390	426	285	318	
11-3/4"	(300)	4-3/4"	(120)	297	333	3-1/2"	390	426	285	318	
14-1/8"	(350)	4-3/4"	(120)	297	333	3-1/2"	390	426	285	318	
15-3/4"	(400)	4-3/4"	(120)	297	333	3-1/2"	390	426	285	318	

¹⁾ Minimum specified bending yield strength, determined in acc. with ASTM F1575 using D_r .
²⁾ For axial capacity determine the minimum of the corresponding adjusted values, $\min\{W; W_H; N\}$; in case of $\alpha < 90^\circ$ apply factor R_{α} .
³⁾ reference lateral design values for single shear connection with loading parallel to grain (dowel bearing strength $F_{e\parallel}$) and perpendicular to grain ($F_{e\perp}$), determined with D_r .
⁴⁾ Assumed steel plate thickness $t_{s,s} = 0.236$ in; the steel plate has to be verified separately

and according to corresponding steel standards.
⁵⁾ Values for threaded length completely located in lower component and equal specific gravity of both members.
 Typos and printing errors reserved. The values stated in combination with geometric requirements, instruction and all further notes are meant to serve as planning guides; projects should only be undertaken by authorised designers and professionals.

5/16" RAPID® fullthread countersunk head

T-drive (T40), countersunk head, milling ribs, single thread, compressor, half tip, YellWin 500+ coating



D_{nom}	D	D_H	D_r	N_a	N_u	$F_{yb,spec}^{1)}$
in (mm)	in	in	in	lbf	lbf	psi
5/16" (8)	0.315	0.591	0.205	1,920	2,890	209,300

	$L_{emb,w}$	W_{90}
	in	lbf/in
$SG_{NDS} = 0.42$	≥ 1.89	160
$SG_{NDS} = 0.50$	≥ 1.89	181
LVL of DFir* $SG_{eg} = 0.50$	≥ 1.89	197

* acc. to ESR-1040

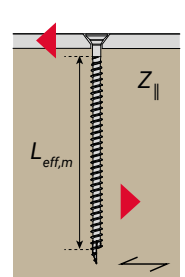
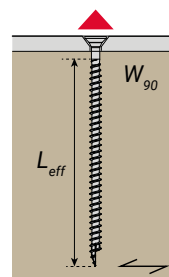
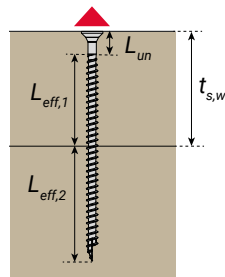
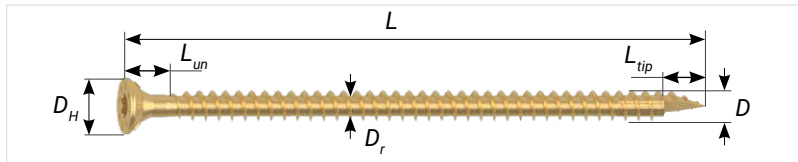

$D_{nom} = 5/16"$ (8 mm)				AXIAL 90° ²⁾									LATERAL ³⁾	
				WOOD-TO-WOOD					STEEL-TO-WOOD ⁴⁾				STEEL-TO-WOOD ⁴⁾	
L		L_{un}	L_{tip}	$t_{s,w}$ 0.5·L	min { $W_{90} \cdot N_a$ }			$L_{eff} = L - L_{un}$ ⁴⁾	min { $W_{90} \cdot N_a$ }			$Z_{ }$ ⁴⁾		
					SG_{NDS} 0.42	SG_{NDS} 0.50	LVL of DFir* $SG_{eg} = 0.50$		SG_{NDS} 0.42	SG_{NDS} 0.50	LVL of DFir* $SG_{eg} = 0.50$	SG_{NDS} 0.42	SG_{NDS} 0.50	
in	(mm)	in	in	in	lbf	lbf	lbf	in	lbf	lbf	lbf	lbf	lbf	
4-3/4"	(120)	0.394	0.433	2.36	315	356	388	4.33	693	879	853	308	355	
5-1/2"	(140)	0.394	0.433	2.76	378	428	465	5.12	819	1039	1008	308	355	
6-1/4"	(160)	0.394	0.433	3.15	441	499	543	5.91	1039	1199	1193	308	355	
7-1/8"	(180)	0.394	0.433	3.54	504	570	620	6.69	1178	1359	1352	308	355	
7-7/8"	(200)	0.394	0.433	3.94	567	641	698	7.48	1317	1519	-	308	355	
8-5/8"	(220)	0.394	0.433	4.33	630	713	776	8.27	1455	1678	-	308	355	
9-1/2"	(240)	0.394	0.433	4.72	693	784	853	9.06	1594	1838	-	308	355	
10-1/4"	(260)	0.394	0.433	5.12	756	855	931	9.84	1732	1920	-	308	355	
11"	(280)	0.394	0.433	5.51	819	926	1008	10.63	1871	1920	-	308	355	
11-3/4"	(300)	0.394	0.433	5.91	882	998	1086	11.42	1920	1920	-	308	355	
12-3/4"	(325)	0.394	0.433	6.40	961	1087	1183	12.40	1920	1920	-	308	355	
13-3/4"	(350)	0.394	0.433	6.89	1039	1176	1280	13.39	1920	1920	-	308	355	
14-3/4"	(375)	0.394	0.433	7.38	1118	1265	-	14.37	1920	1920	-	308	355	
15-3/4"	(400)	0.394	0.433	7.87	1197	1354	-	15.35	1920	1920	-	308	355	
17-3/4"	(450)	0.906	0.433	8.86	1272	1439	-	16.85	1920	1920	-	308	355	
19-5/8"	(500)	0.906	0.433	9.84	1430	1618	-	18.82	1920	1920	-	308	355	
23-5/8"	(600)	0.906	0.433	11.81	1745	1920	-	22.76	1920	1920	-	308	355	

¹⁾ Minimum specified bending yield strength, determined in acc. with ASTM F1575 using D_r .

²⁾ For axial capacity determine the minimum of the corresponding adjusted values, min{ $W; N$ }; in case of $\alpha < 90^\circ$ apply factor R_α ;

³⁾ Reference lateral design values for single shear connection with loading parallel to grain (dowel bearing strength $F_{e||}$) and perpendicular to grain ($F_{e\perp}$) according to NDS; determined with D_r .

⁴⁾ Assumed steel plate thickness $t_{s,w} = 0.236$ inch; the steel plate has to be verified separately and according to corresponding steel standards.

Typos and printing errors reserved. The values stated in combination with geometric requirements, instruction and all further notes are meant to serve as planning guides; projects should only be undertaken by authorised professionals.

5/16" RAPID® fullthread countersunk head

T-drive (T40), countersunk head, milling ribs, single thread, compressor, half tip, YellWin 500+ coating



D_{nom}	D	D_H	D_r	N_a	N_u	$F_{yb,spec}^{1)}$
in (mm)	in	in	in	lbf	lbf	psi
5/16" (8)	0.315	0.591	0.205	1,920	2,890	209,300

	$L_{emb,w}$	W_{90}
	in	lbf/in
$SG_{NDS} = 0.42$	≥ 1.89	160
$SG_{NDS} = 0.50$	≥ 1.89	181
LVL of DFir* $SG_{eg} = 0.50$	≥ 1.89	197

* acc. to ESR-1040

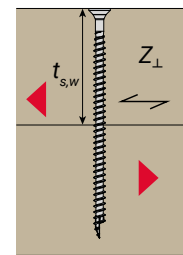
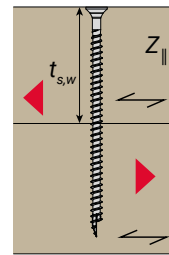
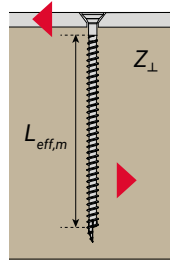
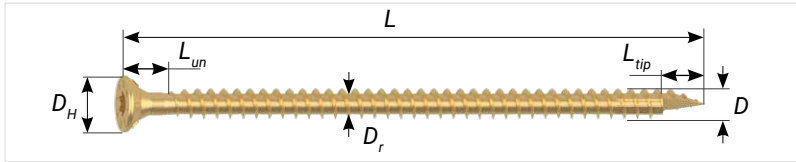

$D_{nom} = 5/16"$ (8 mm)		LATERAL ³⁾						
		STEEL-TO-WOOD			WOOD-TO-WOOD			
		$Z_{\perp}^{4)}$		$t_{s,w}$	Z_{\parallel}		$Z_{\perp,m}$	
SG_{NDS} 0.42	SG_{NDS} 0.50	SG_{NDS} 0.42	SG_{NDS} 0.50		SG_{NDS} 0.42	SG_{NDS} 0.50		
L								
in	(mm)	lbf	lbf	in	lbf	lbf	lbf	lbf
4-3/4"	(120)	246	284	-	-	-	-	-
5-1/2"	(140)	246	284	-	-	-	-	-
6-1/4"	(160)	246	284	-	-	-	-	-
7-1/8"	(180)	246	284	3.54	252	296	202	237
7-7/8"	(200)	246	284	3.94	252	296	202	237
8-5/8"	(220)	246	284	4.33	252	296	202	237
9-1/2"	(240)	246	284	4.72	252	296	202	237
10-1/4"	(260)	246	284	5.12	252	296	202	237
11"	(280)	246	284	5.51	252	296	202	237
11-3/4"	(300)	246	284	5.91	252	296	202	237
12-3/4"	(325)	246	284	6.40	252	296	202	237
13-3/4"	(350)	246	284	6.89	252	296	202	237
14-3/4"	(375)	246	284	7.38	252	296	202	237
15-3/4"	(400)	246	284	7.87	252	296	202	237
17-3/4"	(450)	246	284	8.86	252	296	202	237
19-5/8"	(500)	246	284	9.84	252	296	202	237
23-5/8"	(600)	246	284	11.81	252	296	202	237

¹⁾ Minimum specified bending yield strength, determined in acc. with ASTM F1575 using D_r .

²⁾ For axial capacity determine the minimum of the corresponding adjusted values, $\min(W; N)$; in case of $\alpha < 90^\circ$ apply factor R_α ;

³⁾ Reference lateral design values for single shear connection with loading parallel to grain (dowel bearing strength $F_{e\parallel}$) and perpendicular to grain ($F_{e\perp}$) according to NDS; determined with D_r .

⁴⁾ Assumed steel plate thickness $t_{s,w} = 0.236$ inch; the steel plate has to be verified separately and according to corresponding steel standards.

Typos and printing errors reserved. The values stated in combination with geometric requirements, instruction and all further notes are meant to serve as planning guides; projects should only be undertaken by authorised professionals.

5/16" RAPID® fullthread countersunk head

T-drive (T40), countersunk head, milling ribs, single thread, compressor, half tip, YellWin 500+ coating



D_{nom}	D	D_H	D_r	N_a	N_u	$F_{yb,spec}^{1)}$
in (mm)	in	in	in	lbf	lbf	psi
5/16" (8)	0.315	0.591	0.205	1,920	2,890	209,300

	$L_{emb,w}$	W_{90}
	in	lbf/in
$SG_{NDS} = 0.42$	≥ 1.89	160
$SG_{NDS} = 0.50$	≥ 1.89	181
LVL of DFir* $SG_{eg} = 0.50$	≥ 1.89	197

* acc. to ESR-1040

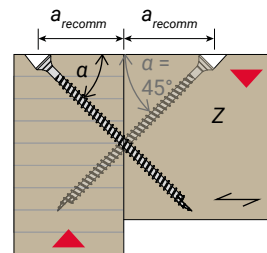
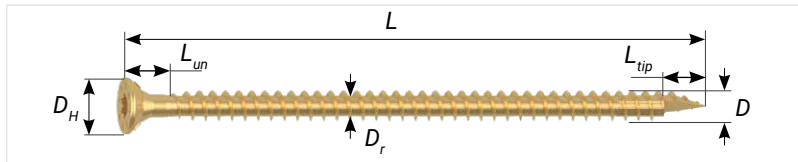

$D_{nom} = 5/16"$ (8 mm)		MAINLY AXIAL 45° ²⁾			
		1 SYMMETRIC SCREW PAIR			
L	a_{recomm}	Z			
		$SG_{NDS} 0.42$	$SG_{NDS} 0.50$	LVL of DFir* $SG_{eg} = 0.50$	
in	(mm)	lbf	lbf	lbf	
4-3/4"	(120)	-	-	-	
5-1/2"	(140)	-	-	-	
6-1/4"	(160)	-	-	-	
7-1/8"	(180)	-	-	-	
7-7/8"	(200)	-	-	-	
8-5/8"	(220)	10.5D ³⁾	821 ³⁾	929 ³⁾	
9-1/2"	(240)	11.5D ³⁾	913 ³⁾	1033 ³⁾	
10-1/4"	(260)	12.5D ³⁾	1005 ³⁾	1137 ³⁾	
11"	(280)	13.5D ³⁾	1092 ³⁾	1236 ³⁾	
11-3/4"	(300)	14.0D ³⁾	1142 ³⁾	1292 ³⁾	
12-3/4"	(325)	15.5D ³⁾	1274 ³⁾	1441 ³⁾	
13-3/4"	(350)	16.5D ³⁾	1372 ³⁾	1552 ³⁾	
14-3/4"	(375)	17.5D ³⁾	1463 ³⁾	1655 ³⁾	
15-3/4"	(400)	18.5D ³⁾	1555 ³⁾	1759 ³⁾	
17-3/4"	(450)	21.0D ³⁾	1687 ³⁾	1909 ³⁾	
19-5/8"	(500)	23.0D	1871	2116	
23-5/8"	(600)	27.5D	2283	2583	

¹⁾ Minimum specified bending yield strength, determined in acc. with ASTM F1575 using D_r .

²⁾ Recommended distance from the end to the screw axis. To follow the distance requirements according to ICC-ESR-4549 with $a_{end,CG} \geq 10D$ in a connection of a main and a secondary beam with a symmetric screw pair requires screw lengths over or equal to $58D$ with appropriate wood member dimensions. The capacity result of a screw loaded in tension and one loaded in compression. Note, the characteristic buckling capacity $k_c \cdot N_{plk}$ is determined according to ETA-12/0373:2022 considers a lower bending yield strength than according to ICC-ESR-4549. Z is determined as:
 $(\min \{W_{45^\circ} \cdot N\} + \min \{W_{45^\circ} \cdot N; (k_c \cdot N_{plk})\}) \cdot \sin 45^\circ$ with $k_c \cdot N_{plk} = 2,713$ lbf for $SG_{NDS} = 0.42$,
 $k_c \cdot N_{plk} = 2,843$ lbf for $SG_{NDS} = 0.50$ and $k_c \cdot N_{plk} = 2,872$ lbf for LVL of DFir with $SG_{eg} = 0.50$.

³⁾ Given values for a_{recomm} and design values base on requirements according to ETA-12/0373:2022.

These applications are not covered by ICC-ESR-4549: IT IS ON THE RESPONSIBILITY OF THE QUALIFIED DESIGNER TO APPLY INCLINED SCREWS, TO CHOSE ADEQUAT DISTANCES, TO CONSIDER SCREWS LOADED IN COMPRESSION, AS WELL AS TO JUSTIFY THE CONNECTION GEOMETRY, ALL TO THE SATISFACTION OF THE CODE OFFICIAL. Typos and printing errors reserved. The values stated in combination with geometric requirements, instruction and all further notes are meant to serve as planning guides; projects should only be undertaken by authorised designer and professionals.

5/16" RAPID® fullthread countersunk head

T-drive (T40), countersunk head, milling ribs, single thread, compressor, half tip, YellWin 500+ coating



D_{nom}	D	D_H	D_r	N_a	N_u	$F_{yb,spec}^{1)}$
in (mm)	in	in	in	lbf	lbf	psi
5/16" (8)	0.315	0.591	0.205	1,920	2,890	209,300

	$L_{emb,w}$	W_{90}
	in	lbf/in
$SG_{NDS} = 0.42$	≥ 1.89	160
$SG_{NDS} = 0.50$	≥ 1.89	181
LVL of DFir* $SG_{eg} = 0.50$	≥ 1.89	197

* acc. to ESR-1040

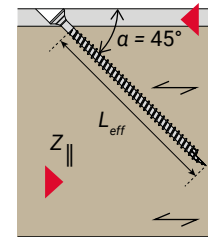
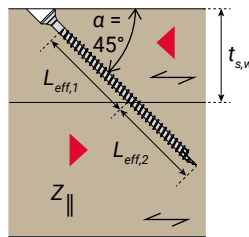
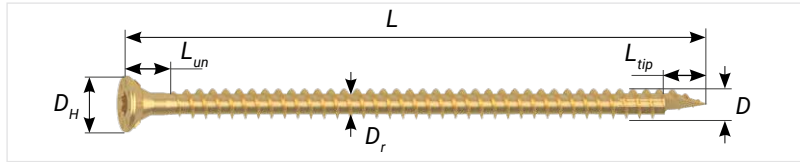

$D_{nom} = 5/16"$ (8 mm)		MAINLY AXIAL 45° 4)						
		WOOD-TO-WOOD with $\min\{L_{eff,1}, L_{eff,2}\}$			STEEL-TO-WOOD ⁵⁾			
L		$t_{s,w}$	$Z_{ } = \min\{W_{45}, N_a\} \cdot \cos 45^\circ$			$Z_{ } = \min\{W_{45}, N_a\} \cdot \cos 45^\circ$		
			SG_{NDS} 0.42	SG_{NDS} 0.50	LVL of DFir* $SG_{eg} = 0.50$	SG_{NDS} 0.42	SG_{NDS} 0.50	LVL of DFir* $SG_{eg} = 0.50$
in	(mm)	in	lbf	lbf	lbf	lbf	lbf	lbf
4-3/4"	(120)	1.97	216	244	265	430	486	529
5-1/2"	(140)	1.97	216	244	265	511	578	629
6-1/4"	(160)	2.36	273	309	336	592	669	729
7-1/8"	(180)	2.36	273	309	336	673	761	828
7-7/8"	(200)	2.36	273	309	336	754	853	928
8-5/8"	(220)	3.15	388	438	477	835	945	1028
9-1/2"	(240)	3.15	388	438	477	916	1036	1128
10-1/4"	(260)	3.15	388	438	477	997	1128	1228
11"	(280)	3.94	502	568	618	1078	1220	-
11-3/4"	(300)	3.94	502	568	618	1159	1311	-
12-3/4"	(325)	4.72	617	698	760	1261	1358	-
13-3/4"	(350)	4.72	617	698	760	1358	1358	-
14-3/4"	(375)	5.51	732	828	901	1358	1358	-
15-3/4"	(400)	5.51	732	828	901	1358	1358	-
17-3/4"	(450)	6.30	793	898	977	1358	1358	-
19-5/8"	(500)	7.09	908	1027	-	1358	1358	-
23-5/8"	(600)	7.87	1023	1157	-	1358	1358	-

⁴⁾ On responsibility of the qualified designer, friction can be considered as proposed in ETA-12/0373:2022 by a friction coefficient of $\mu = 0.25$. In this case, tabulated values can be justified to rely on friction with factor $(\sin 45^\circ + \mu \cdot \cos 45^\circ) / \sin 45^\circ = 1.30$.

⁵⁾ To ensure sufficient steel plate thickness L_{eff} is reduced by $0.5D$ to determine W_{45} ; The capacity of the steel plate must be verified separately and according to corresponding steel standards.

These applications are not covered by ICC-ESR-4549: IT IS ON THE RESPONSIBILITY OF THE QUALIFIED DESIGNER TO APPLY INCLINED SCREWS, TO CHOSE ADEQUAT DISTANCES, TO CONSIDER FRICTION LOADS, AS WELL AS TO JUSTIFY THE CONNECTION GEOMETRY, ALL TO THE SATISFACTION OF THE CODE OFFICIAL. Typos and printing errors reserved. The values stated in combination with geometric requirements, instruction and all further notes are meant to serve as planning guides; projects should only be undertaken by authorised designer and professionals.

3/8" RAPID® fullthread countersunk head

T-drive (T50), countersunk head, milling ribs, single thread, compressor, half tip, YellWin 500+ coating



D_{nom}	D	D_H	D_r	N_a	N_u	$F_{yb,spec}^{1)}$
in (mm)	in	in	in	lbf	lbf	psi
3/8" (10)	0.394	0.728	0.240	3,490	5,240	206,400

	$L_{emb,w}$	W_{90}
	in	lbf/in
$SG_{NDS} = 0.42$	≥ 2.36	182
$SG_{NDS} = 0.50$	≥ 2.36	224
LVL of DFir* $SG_{eg} = 0.50$	≥ 2.36	197

* acc. to ESR-1040

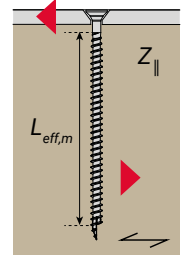
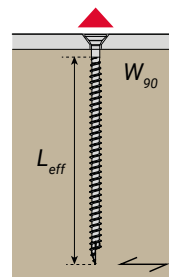
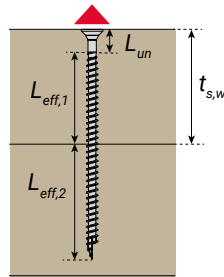
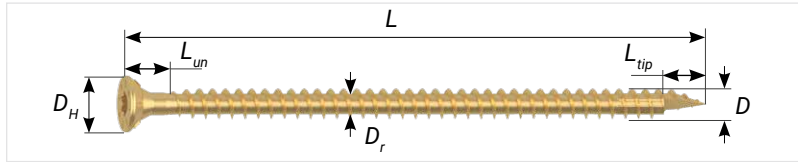

$D_{nom} = 3/8"$ (10 mm)				AXIAL 90° ²⁾								LATERAL ³⁾	
				WOOD-TO-WOOD				STEEL-TO-WOOD ⁴⁾				STEEL-TO-WOOD ⁴⁾	
L		L_{un}	L_{tip}	$t_{s,w}$ 0.5·L	min { $W_{90}; N_a$ }			$L_{eff} =$ $L - L_{un}$ ⁴⁾	min { $W_{90}; N_a$ }			$Z_{ }$ ⁴⁾	
					SG_{NDS} 0.42	SG_{NDS} 0.50	LVL of DFir* $SG_{eg} = 0.50$		SG_{NDS} 0.42	SG_{NDS} 0.50	LVL of DFir* $SG_{eg} = 0.50$	SG_{NDS} 0.42	SG_{NDS} 0.50
in	(mm)	in	in	in	lbf	lbf	lbf	in	lbf	lbf	lbf	lbf	lbf
4-3/4"	(120)	0.473	0.512	2.36	-	-	-	4.25	774	952	838	349	403
6-1/4"	(160)	0.473	0.512	3.15	487	600	527	5.83	1060	1305	1148	349	403
7-1/8"	(180)	0.473	0.512	3.54	559	688	605	6.61	1204	1482	1303	349	403
7-7/8"	(200)	0.473	0.512	3.94	631	776	683	7.40	1584	1658	-	349	403
8-5/8"	(220)	0.473	0.512	4.33	702	864	760	8.19	1752	1834	-	349	403
9-1/2"	(240)	0.473	0.512	4.72	774	953	838	8.98	1921	2011	-	349	403
10-1/4"	(260)	0.473	0.512	5.12	846	1041	915	9.76	2089	2187	-	349	403
11"	(280)	0.473	0.512	5.51	917	1129	993	10.55	2258	2363	-	349	403
11-3/4"	(300)	0.473	0.512	5.91	989	1217	1070	11.34	2426	2540	-	349	403
12-3/4"	(325)	0.945	0.512	6.40	992	1221	1074	11.85	2536	2654	-	349	403
13-3/4"	(350)	0.945	0.512	6.89	1082	1332	1171	12.83	2747	2875	-	349	403
14-3/4"	(375)	0.945	0.512	7.38	1172	1442	-	13.82	2957	3095	-	349	403
15-3/4"	(400)	0.945	0.512	7.87	1261	1552	-	14.80	3168	3316	-	349	403
17-3/4"	(450)	0.945	0.512	8.86	1440	1773	-	16.77	3490	3490	-	349	403
19-5/8"	(500)	0.945	0.512	9.84	1619	1993	-	18.74	3490	3490	-	349	403
23-5/8"	(600)	0.945	0.512	11.81	1978	2434	-	22.68	3490	3490	-	349	403
27-5/8"	(700)	0.945	0.512	13.78	2336	2875	-	26.61	3490	3490	-	349	403
31-1/2"	(800)	0.945	0.512	15.75	2694	3316	-	30.55	3490	3490	-	349	403
39-3/8"	(1000)	0.945	0.512	19.69	3411	3490	-	38.43	3490	3490	-	349	403

¹⁾ Minimum specified bending yield strength, determined in acc. with ASTM F1575 using D_r .

²⁾ For axial capacity determine the minimum of the corresponding adjusted values, min{ $W; N$ }; in case of $\alpha < 90^\circ$ apply factor R_α ;

³⁾ Reference lateral design values for single shear connection with loading parallel to grain (dowel bearing strength $F_{e||}$) and perpendicular to grain ($F_{e\perp}$) according to NDS; determined with D_r .

⁴⁾ Assumed steel plate thickness $t_{s,w} = 0.236$ inch; the steel plate has to be verified separately and according to corresponding steel standards.

Typos and printing errors reserved. The values stated in combination with geometric requirements, instruction and all further notes are meant to serve as planning guides; projects should only be undertaken by authorised professionals.

3/8" RAPID® fullthread countersunk head

T-drive (T50), countersunk head, milling ribs, single thread, compressor, half tip, YellWin 500+ coating



D_{nom}	D	D_H	D_r	N_a	N_u	$F_{yb,spec}^{1)}$
in (mm)	in	in	in	lbf	lbf	psi
3/8" (10)	0.394	0.728	0.240	3,490	5,240	206,400

	$L_{emb,w}$	W_{90}
	in	lbf/in
$SG_{NDS} = 0.42$	≥ 2.36	182
$SG_{NDS} = 0.50$	≥ 2.36	224
LVL of DFir* $SG_{eg} = 0.50$	≥ 2.36	197

* acc. to ESR-1040

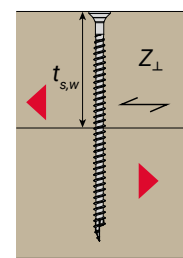
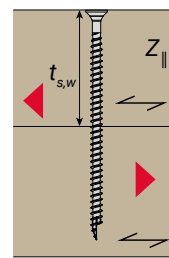
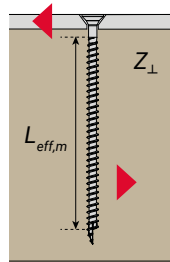
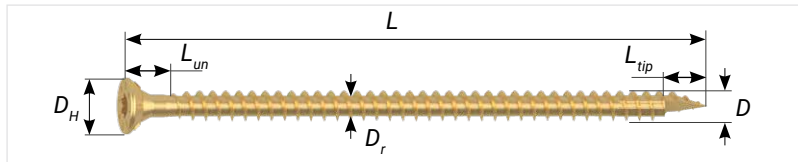

$D_{nom} = 3/8"$ (10 mm)		LATERAL ³⁾						
		STEEL-TO-WOOD			WOOD-TO-WOOD			
		$Z_{\perp}^{4)}$		$t_{s,w}$	Z_{\parallel}		$Z_{\perp,m}$	
SG_{NDS} 0.42	SG_{NDS} 0.50	SG_{NDS} 0.42	SG_{NDS} 0.50		SG_{NDS} 0.42	SG_{NDS} 0.50		
L		lbf	lbf	in	lbf	lbf	lbf	lbf
in	(mm)							
4-3/4"	(120)	279	322	-	-	-	-	-
6-1/4"	(160)	279	322	-	-	-	-	-
7-1/8"	(180)	279	322	3.54	302	355	242	284
7-7/8"	(200)	279	322	3.94	302	355	242	284
8-5/8"	(220)	279	322	4.33	302	355	242	284
9-1/2"	(240)	279	322	4.72	302	355	242	284
10-1/4"	(260)	279	322	5.12	302	355	242	284
11"	(280)	279	322	5.51	302	355	242	284
11-3/4"	(300)	279	322	5.91	302	355	242	284
12-3/4"	(325)	279	322	6.40	302	355	242	284
13-3/4"	(350)	279	322	6.89	302	355	242	284
14-3/4"	(375)	279	322	7.38	302	355	242	284
15-3/4"	(400)	279	322	7.87	302	355	242	284
17-3/4"	(450)	279	322	8.86	302	355	242	284
19-5/8"	(500)	279	322	9.84	302	355	242	284
23-5/8"	(600)	279	322	11.81	302	355	242	284
27-5/8"	(700)	279	322	13.78	302	355	242	284
31-1/2"	(800)	279	322	15.75	302	355	242	284
39-3/8"	(1000)	279	322	19.69	302	355	242	284

¹⁾ Minimum specified bending yield strength, determined in acc. with ASTM F1575 using D_r .
²⁾ For axial capacity determine the minimum of the corresponding adjusted values, $\min(W; N)$; in case of $\alpha < 90^\circ$ apply factor R_α .
³⁾ Reference lateral design values for single shear connection with loading parallel to grain (dowel bearing strength $F_{e\parallel}$) and perpendicular to grain ($F_{e\perp}$) according to NDS; determined with D_r .

⁴⁾ Assumed steel plate thickness $t_{s,w} = 0.236$ inch; the steel plate has to be verified separately and according to corresponding steel standards.
 Typos and printing errors reserved. The values stated in combination with geometric requirements, instruction and all further notes are meant to serve as planning guides; projects should only be undertaken by authorised professionals.

3/8" RAPID® fullthread countersunk head

T-drive (T50), countersunk head, milling ribs, single thread, compressor, half tip, YellWin 500+ coating



D_{nom}	D	D_H	D_r	N_a	N_u	$F_{yb,spec}^{1)}$
in (mm)	in	in	in	lbf	lbf	psi
3/8" (10)	0.394	0.728	0.240	3,490	5,240	206,400

	$L_{emb,w}$	W_{90}
	in	lbf/in
$SG_{NDS} = 0.42$	≥ 2.36	182
$SG_{NDS} = 0.50$	≥ 2.36	224
LVL of DFir* $SG_{eg} = 0.50$	≥ 2.36	197

* acc. to ESR-1040

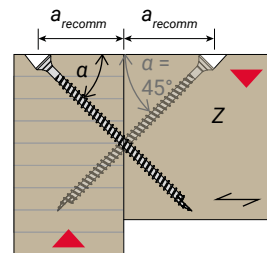
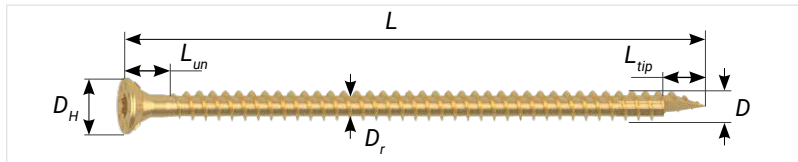

$D_{nom} = 3/8"$ (10 mm)		MAINLY AXIAL 45° ²⁾			
		1 SYMMETRIC SCREW PAIR			
L		a_{recomm}	Z		
			$SG_{NDS} 0.42$	$SG_{NDS} 0.50$	LVL of DFir* $SG_{eg} = 0.50$
in	(mm)		lbf	lbf	lbf
4-3/4"	(120)	-	-	-	-
6-1/4"	(160)	-	-	-	-
7-1/8"	(180)	-	-	-	-
7-7/8"	(200)	-	-	-	-
8-5/8"	(220)	-	-	-	-
9-1/2"	(240)	-	-	-	-
10-1/4"	(260)	-	-	-	-
11"	(280)	11.0D ³⁾	1232 ³⁾	1516 ³⁾	-
11-3/4"	(300)	11.5D ³⁾	1305 ³⁾	1606 ³⁾	-
12-3/4"	(325)	12.5D ³⁾	1325 ³⁾	1631 ³⁾	-
13-3/4"	(350)	13.5D ³⁾	1455 ³⁾	1791 ³⁾	-
14-3/4"	(375)	14.0D ³⁾	1521 ³⁾	1871 ³⁾	-
15-3/4"	(400)	15.0D ³⁾	1651 ³⁾	2032 ³⁾	-
17-3/4"	(450)	17.0D ³⁾	1912 ³⁾	2353 ³⁾	-
19-5/8"	(500)	18.5D ³⁾	2108 ³⁾	2594 ³⁾	-
23-5/8"	(600)	22.0D	2565	3156	-
27-5/8"	(700)	25.5D	3021	3719	-
31-1/2"	(800)	29.0D	3478	4281	-
39-3/8"	(1000)	36.5D	4457	4936	-

¹⁾ Minimum specified bending yield strength, determined in acc. with ASTM F1575 using D_r .
²⁾ Recommended distance from the end to the screw axis. To follow the distance requirements according to ICC-ESR-4549 with $a_{end,CG} \geq 10D$ in a connection of a main and a secondary beam with a symmetric screw pair requires screw lengths over or equal to $58D$ with appropriate wood member dimensions. The capacity result of a screw loaded in tension and one loaded in compression. Note, the characteristic buckling capacity $k_c \cdot N_{plk}$ is determined according to ETA-12/0373:2022 considers a lower bending yield strength than according to ICC-ESR-4549. Z is determined as:
 $(\min\{W_{45^\circ}, N\} + \min\{W_{45^\circ}, N; (k_c \cdot N_{plk})\}) \cdot \sin 45^\circ$ with $k_c \cdot N_{plk} = 4,045$ lbf for $SG_{NDS} = 0.42$, $k_c \cdot N_{plk} = 4,218$ lbf for $SG_{NDS} = 0.50$ and $k_c \cdot N_{plk} = 4,274$ lbf for LVL of DFir with $SG_{eg} = 0.50$.

³⁾ Given values for a_{recomm} and design values base on requirements according to ETA-12/0373:2022.
 These applications are not covered by ICC-ESR-4549: IT IS ON THE RESPONSIBILITY OF THE QUALIFIED DESIGNER TO APPLY INCLINED SCREWS, TO CHOSE ADEQUAT DISTANCES, TO CONSIDER SCREWS LOADED IN COMPRESSION, AS WELL AS TO JUSTIFY THE CONNECTION GEOMETRY, ALL TO THE SATISFACTION OF THE CODE OFFICIAL.
 Typos and printing errors reserved. The values stated in combination with geometric requirements, instruction and all further notes are meant to serve as planning guides; projects should only be undertaken by authorised designer and professionals.

3/8" RAPID® fullthread countersunk head

T-drive (T50), countersunk head, milling ribs, single thread, compressor, half tip, YellWin 500+ coating



D_{nom}	D	D_H	D_r	N_a	N_u	$F_{yb,spec}^{1)}$
in (mm)	in	in	in	lbf	lbf	psi
3/8" (10)	0.394	0.728	0.240	3,490	5,240	206,400

	$L_{emb,w}$	W_{90}
	in	lbf/in
$SG_{NDS} = 0.42$	≥ 2.36	182
$SG_{NDS} = 0.50$	≥ 2.36	224
LVL of DFir* $SG_{eg} = 0.50$	≥ 2.36	197

* acc. to ESR-1040

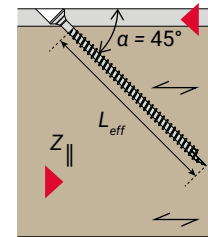
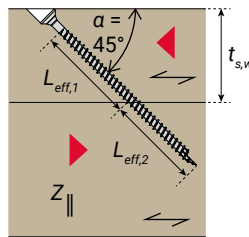
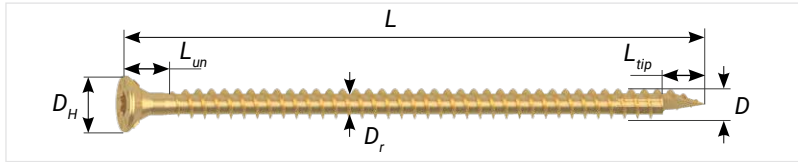

$D_{nom} = 3/8"$ (10 mm)		MAINLY AXIAL 45° ⁴⁾						
		WOOD-TO-WOOD with $\min\{L_{eff,1}, L_{eff,2}\}$					STEEL-TO-WOOD ⁵⁾	
		L	$t_{s,w}$	$Z_{ } = \min\{W_{45}, N_a\} \cdot \cos 45^\circ$			$Z_{ } = \min\{W_{45}, N_a\} \cdot \cos 45^\circ$	
SG_{NDS} 0.42	SG_{NDS} 0.50			LVL of DFir* $SG_{eg} = 0.50$	SG_{NDS} 0.42	SG_{NDS} 0.50	LVL of DFir* $SG_{eg} = 0.50$	
in	(mm)	in	lbf	lbf	lbf	lbf	lbf	lbf
4-3/4"	(120)	1.57	-	-	-	475	584	514
6-1/4"	(160)	2.36	293	361	317	659	811	714
7-1/8"	(180)	2.36	293	361	317	752	925	813
7-7/8"	(200)	2.36	293	361	317	844	1038	913
8-5/8"	(220)	3.15	433	533	469	950	1169	1028
9-1/2"	(240)	3.15	424	522	459	1028	1265	1113
10-1/4"	(260)	3.15	424	522	459	1120	1379	1213
11"	(280)	3.94	554	682	600	1213	1492	-
11-3/4"	(300)	3.94	554	682	600	1305	1606	-
12-3/4"	(325)	4.72	629	774	681	1365	1680	-
13-3/4"	(350)	4.72	629	774	681	1480	1822	-
14-3/4"	(375)	4.72	629	774	681	1595	1963	-
15-3/4"	(400)	5.51	760	935	822	1711	2105	-
17-3/4"	(450)	6.30	890	1095	963	1941	2389	-
19-5/8"	(500)	7.09	1020	1256	-	2172	2468	-
23-5/8"	(600)	7.87	1151	1416	-	2468	2468	-
27-5/8"	(700)	9.45	1412	1737	-	2468	2468	-
31-1/2"	(800)	11.02	1672	2058	-	2468	2468	-
39-3/8"	(1000)	14.17	2194	2468	-	2468	2468	-

⁴⁾ On responsibility of the qualified designer, friction can be considered as proposed in ETA-12/0373:2022 by a friction coefficient of $\mu = 0.25$. In this case, tabulated values can be justified to rely on friction with factor $(\sin 45^\circ + \mu \cdot \cos 45^\circ) / \sin 45^\circ = 1.30$.

⁵⁾ To ensure sufficient steel plate thickness L_{eff} is reduced by $0.5D$ to determine W_{45} ; The capacity of the steel plate must be verified separately and according to corresponding steel standards.

These applications are not covered by ICC-ESR-4549: IT IS ON THE RESPONSIBILITY OF THE QUALIFIED DESIGNER TO APPLY INCLINED SCREWS, TO CHOSE ADEQUAT DISTANCES, TO CONSIDER FRICTION LOADS, AS WELL AS TO JUSTIFY THE CONNECTION GEOMETRY, ALL TO THE SATISFACTION OF THE CODE OFFICIAL. Typos and printing errors reserved. The values stated in combination with geometric requirements, instruction and all further notes are meant to serve as planning guides; projects should only be undertaken by authorised designer and professionals.

1/2" RAPID® fullthread countersunk head

T-drive (T50), countersunk head, milling ribs, single thread, compressor, half tip, YellWin 500+ coating



D_{nom}	D	D_H	D_r	N_a	N_u	$F_{yb,spec}^{1)}$
in (mm)	in	in	in	lbf	lbf	psi
1/2" (12)	0.472	0.827	0.268	3,880	5,820	193,300

	$L_{emb,w}$	W_{90}
	in	lbf/in
$SG_{NDS} = 0.42$	≥ 2.83	223
$SG_{NDS} = 0.50$	≥ 2.84	251
LVL of DFir* $SG_{eg} = 0.50$	≥ 2.84	224

* acc. to ESR-1040

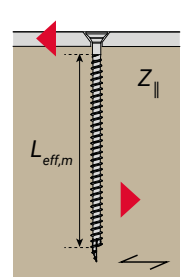
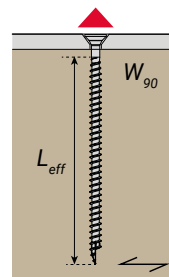
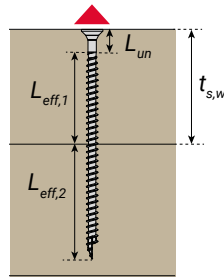
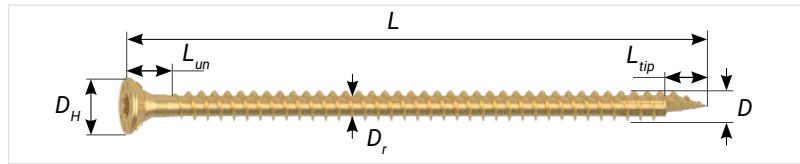

$D_{nom} = 1/2"$ (12 mm)				AXIAL 90° ²⁾					LATERAL ³⁾			
				WOOD-TO-WOOD			STEEL-TO-WOOD ⁴⁾		STEEL-TO-WOOD ⁴⁾			
L		L_{un}	L_{tip}	$t_{s,w}$ 0.5 · L	min { $W_{90}; N_a$ }			$L_{eff} =$ $L - L_{un}$ ⁴⁾	min { $W_{90}; N_a$ }		$Z_{ }$ ⁴⁾	
					SG_{NDS} 0.42	SG_{NDS} 0.50	LVL of DFir* $SG_{eg} = 0.50$		SG_{NDS} 0.42	SG_{NDS} 0.50	SG_{NDS} 0.42	SG_{NDS} 0.50
in	(mm)	in	in	in	lbf	lbf	lbf	in	lbf	lbf	lbf	lbf
7-7/8"	200	0.787	0.591	3.937	702	791	706	7.09	1580	1779	433	467
8-5/8"	220	0.787	0.591	4.331	790	889	794	7.87	1756	1976	433	467
9-1/2"	240	0.787	0.591	4.724	878	988	882	8.66	1931	2174	433	467
10-1/4"	260	0.787	0.591	5.118	966	1087	970	9.45	2107	2372	433	467
11"	280	0.787	0.591	5.512	1054	1186	1058	10.24	2283	2569	433	467
11-3/4"	300	0.787	0.591	5.906	1141	1285	1147	11.02	2458	2767	433	467
13-3/4"	350	0.787	0.591	6.890	1361	1532	1367	12.99	2897	3261	433	467
15-3/4"	400	0.787	0.591	7.874	1580	1779	-	14.96	3336	3755	433	467
19-5/8"	500	0.787	0.591	9.843	2019	2273	-	18.90	3880	3880	433	467
23-5/8"	600	0.787	0.591	11.811	2458	2767	-	22.83	3880	3880	433	467
27-5/8"	700	0.787	0.591	13.780	2897	3261	-	26.77	3880	3880	433	467
31-1/2"	800	0.787	0.591	15.748	3336	3755	-	30.71	3880	3880	433	467
39-3/8"	1000	0.787	0.591	19.685	3880	3880	-	38.58	3880	3880	433	467

¹⁾ Minimum specified bending yield strength, determined in acc. with ASTM F1575 using D_r .
²⁾ For axial capacity determine the minimum of the corresponding adjusted values, min{ $W; N$ }; in case of $\alpha < 90^\circ$ apply factor R_g .
³⁾ Reference lateral design values for single shear connection with loading parallel to grain (dowel bearing strength $F_{e||}$) and perpendicular to grain ($F_{e\perp}$) according to NDS; determined with D_r .

⁴⁾ Assumed steel plate thickness $t_{s,s} = 0.236$ inch; the steel plate has to be verified separately and according to corresponding steel standards.
 Typos and printing errors reserved. The values stated in combination with geometric requirements, instruction and all further notes are meant to serve as planning guides; projects should only be undertaken by authorised professionals.

1/2" RAPID® fullthread countersunk head

T-drive (T50), countersunk head, milling ribs, single thread, compressor, half tip, YellWin 500+ coating



D_{nom}	D	D_H	D_r	N_a	N_u	$F_{yb,spec}^{1)}$
in (mm)	in	in	in	lbf	lbf	psi
1/2" (12)	0.472	0.827	0.268	3,880	5,820	193,300

	$L_{emb,w}$	W_{90}
	in	lbf/in
$SG_{NDS} = 0.42$	≥ 2.83	223
$SG_{NDS} = 0.50$	≥ 2.84	251
LVL of DFir* $SG_{eg} = 0.50$	≥ 2.84	224

* acc. to ESR-1040

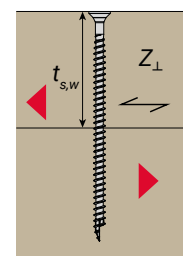
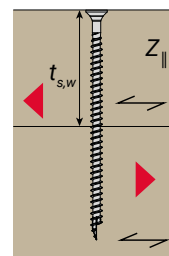
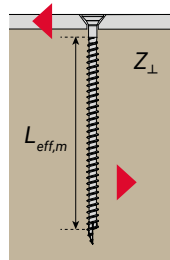
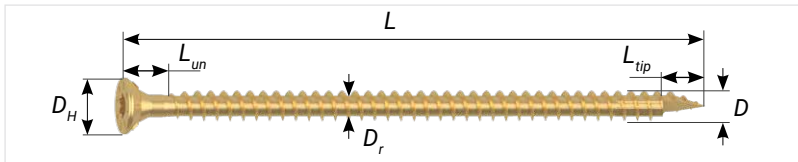

$D_{nom} = 1/2"$ (12 mm)		LATERAL ³⁾						
		STEEL-TO-WOOD			WOOD-TO-WOOD			
L		$Z_{\perp}^{4)}$		$t_{s,w}$	Z_{\parallel}		$Z_{\perp,m}$	
		$SG_{NDS} 0.42$	$SG_{NDS} 0.50$		$SG_{NDS} 0.42$	$SG_{NDS} 0.50$	$SG_{NDS} 0.42$	$SG_{NDS} 0.50$
in	(mm)	lbf	lbf	in	lbf	lbf	lbf	lbf
7-7/8"	200	298	333	3.94	391	426	285	318
8-5/8"	220	298	333	4.33	391	426	285	318
9-1/2"	240	298	333	4.72	391	426	285	318
10-1/4"	260	298	333	5.12	391	426	285	318
11"	280	298	333	5.51	391	426	285	318
11-3/4"	300	298	333	5.91	391	426	285	318
13-3/4"	350	298	333	6.89	391	426	285	318
15-3/4"	400	298	333	7.87	391	426	285	318
19-5/8"	500	298	333	9.84	391	426	285	318
23-5/8"	600	298	333	11.81	391	426	285	318
27-5/8"	700	298	333	13.78	391	426	285	318
31-1/2"	800	298	333	15.75	391	426	285	318
39-3/8"	1000	298	333	19.69	391	426	285	318

¹⁾ Minimum specified bending yield strength, determined in acc. with ASTM F1575 using D_r .

²⁾ For axial capacity determine the minimum of the corresponding adjusted values, $\min(W; N)$; in case of $\alpha < 90^\circ$ apply factor R_g ;

³⁾ Reference lateral design values for single shear connection with loading parallel to grain (dowel bearing strength $F_{e\parallel}$) and perpendicular to grain ($F_{e\perp}$) according to NDS; determined with D_r .

⁴⁾ Assumed steel plate thickness $t_{s,w} = 0.236$ inch; the steel plate has to be verified separately and according to corresponding steel standards.

Typos and printing errors reserved. The values stated in combination with geometric requirements, instruction and all further notes are meant to serve as planning guides; projects should only be undertaken by authorised professionals.

1/2" RAPID® fullthread countersunk head

T-drive (T50), countersunk head, milling ribs, single thread, compressor, half tip, YellWin 500+ coating



D_{nom}	D	D_H	D_r	N_a	N_u	$F_{yb,spec}^{1)}$
in (mm)	in	in	in	lbf	lbf	psi
1/2" (12)	0.472	0.827	0.268	3,880	5,820	193,300

	$L_{emb,w}$	W_{90}
	in	lbf/in
$SG_{NDS} = 0.42$	≥ 2.83	223
$SG_{NDS} = 0.50$	≥ 2.84	251
LVL of DFir* $SG_{eg} = 0.50$	≥ 2.84	224

* acc. to ESR-1040

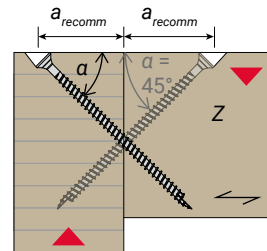
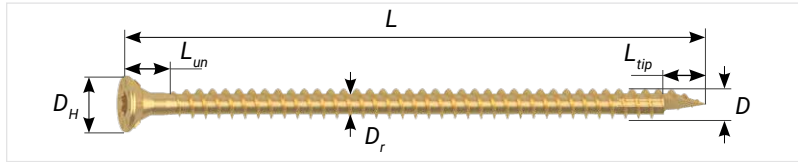

$D_{nom} = 1/2"$ (12 mm)		MAINLY AXIAL 45° ²⁾		
		1 SYMMETRIC SCREW PAIR		
L	a_{recomm}	Z		
		$SG_{NDS} 0.42$	$SG_{NDS} 0.50$	LVL of DFir* $SG_{eg} = 0.50$
in	(mm)	lbf	lbf	lbf
7-7/8"	(200)	-	-	-
8-5/8"	(220)	-	-	-
9-1/2"	(240)	-	-	-
10-1/4"	(260)	-	-	-
11"	(280)	-	-	-
11-3/4"	(300)	-	-	-
13-3/4"	(350)	11.5D ³⁾	1858 ³⁾	2092 ³⁾
15-3/4"	(400)	12.5D ³⁾	2050 ³⁾	2307 ³⁾
19-5/8"	(500)	15.5D ³⁾	2625 ³⁾	2954 ³⁾
23-5/8"	(600)	18.5D ³⁾	3199 ³⁾	3601 ³⁾
27-5/8"	(700)	21.5D	3774	4248
31-1/2"	(800)	24.5D	4349	4895
39-3/8"	(1000)	30.5D	5487	5487

¹⁾ Minimum specified bending yield strength, determined in acc. with ASTM F1575 using D_r .

²⁾ Recommended distance from the end to the screw axis. To follow the distance requirements according to ICC-ESR-4549 with $a_{end,CG} \geq 10D$ in a connection of a main and a secondary beam with a symmetric screw pair requires screw lengths over or equal to 58D with appropriate wood member dimensions. The capacity result of a screw loaded in tension and one loaded in compression. Note, the characteristic buckling capacity $k_c \cdot N_{plk}$ is determined according to ETA-12/0373:2022 considers a lower bending yield strength than according to ICC-ESR-4549. Z is determined as:
 $(\min\{W_{45}; N\} + \min\{W_{45}; N; (k_c \cdot N_{plk})\}) \cdot \sin 45^\circ$ with $k_c \cdot N_{plk} = 5,130$ lbf for $SG_{NDS} = 0.42$,
 $k_c \cdot N_{plk} = 5,343$ lbf for $SG_{NDS} = 0.50$ and $k_c \cdot N_{plk} = 5,412$ lbf for LVL of DFir with $SG_{eg} = 0.50$.

³⁾ Given values for a_{recomm} and design values base on requirements according to ETA-12/0373:2022.

These applications are not covered by ICC-ESR-4549: IT IS ON THE RESPONSIBILITY OF THE QUALIFIED DESIGNER TO APPLY INCLINED SCREWS, TO CHOSE ADEQUAT DISTANCES, TO CONSIDER SCREWS LOADED IN COMPRESSION, AS WELL AS TO JUSTIFY THE CONNECTION GEOMETRY, ALL TO THE SATISFACTION OF THE CODE OFFICIAL. Typos and printing errors reserved. The values stated in combination with geometric requirements, instruction and all further notes are meant to serve as planning guides; projects should only be undertaken by authorised designer and professionals.

1/2" RAPID[®] fullthread countersunk head

T-drive (T50), countersunk head, milling ribs, single thread, compressor, half tip, YellWin 500+ coating



D_{nom}	D	D_H	D_r	N_a	N_u	$F_{yb,spec}^{1)}$
in (mm)	in	in	in	lbf	lbf	psi
1/2" (12)	0.472	0.827	0.268	3,880	5,820	193,300

	$L_{emb,w}$	W_{90}
	in	lbf/in
$SG_{NDS} = 0.42$	≥ 2.83	223
$SG_{NDS} = 0.50$	≥ 2.84	251
LVL of DFir* $SG_{eg} = 0.50$	≥ 2.84	224

* acc. to ESR-1040

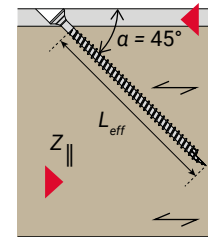
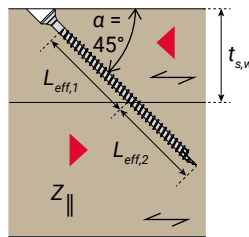
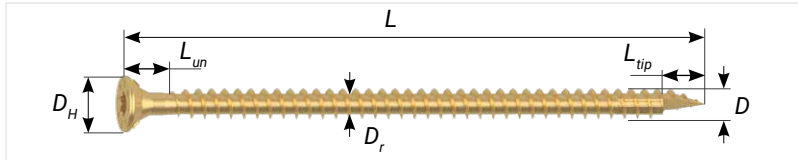

$D_{nom} = 1/2''$ (12 mm)		MAINLY AXIAL 45° ⁴⁾						
		WOOD-TO-WOOD with $\min\{L_{eff,1}, L_{eff,2}\}$				STEEL-TO-WOOD ⁵⁾		
L		$t_{s,w}$	$Z_{ } = \min\{W_{45}, N_a\} \cdot \cos 45^\circ$			$Z_{ } = \min\{W_{45}, N_a\} \cdot \cos 45^\circ$		
			SG_{NDS} 0.42	SG_{NDS} 0.50	LVL of DFir* $SG_{eg} = 0.50$	SG_{NDS} 0.42	SG_{NDS} 0.50	LVL of DFir* $SG_{eg} = 0.50$
in	(mm)	in	lbf	lbf	lbf	lbf	lbf	lbf
7-7/8"	(200)	2.36	-	-	-	983	1106	987
8-5/8"	(220)	3.15	467	526	469	1096	1234	1101
9-1/2"	(240)	3.15	467	526	469	1209	1361	1214
10-1/4"	(260)	3.15	467	526	469	1322	1488	1328
11"	(280)	3.94	627	705	629	1435	1615	-
11-3/4"	(300)	3.94	627	705	629	1548	1742	-
13-3/4"	(350)	4.72	786	885	790	1830	2060	-
15-3/4"	(400)	5.51	946	1065	950	2113	2378	-
19-5/8"	(500)	7.09	1266	1425	-	2678	2744	-
23-5/8"	(600)	7.87	1426	1605	-	2744	2744	-
27-5/8"	(700)	9.45	1745	1964	-	2744	2744	-
31-1/2"	(800)	11.02	2065	2324	-	2744	2744	-
39-3/8"	(1000)	14.17	2704	2744	-	2744	2744	-

⁴⁾ On responsibility of the qualified designer, friction can be considered as proposed in ETA-12/0373:2022 by a friction coefficient of $\mu = 0.25$. In this case, tabulated values can be justified to rely on friction with factor $(\sin 45^\circ + \mu \cdot \cos 45^\circ) / \sin 45^\circ = 1.30$.

⁵⁾ To ensure sufficient steel plate thickness L_{eff} is reduced by $0.5D$ to determine W_{45} ; The capacity of the steel plate must be verified separately and according to corresponding steel standards.

These applications are not covered by ICC-ESR-4549: IT IS ON THE RESPONSIBILITY OF THE QUALIFIED DESIGNER TO APPLY INCLINED SCREWS, TO CHOSE ADEQUAT DISTANCES, TO CONSIDER FRICTION LOADS, AS WELL AS TO JUSTIFY THE CONNECTION GEOMETRY, ALL TO THE SATISFACTION OF THE CODE OFFICIAL. Typos and printing errors reserved. The values stated in combination with geometric requirements, instruction and all further notes are meant to serve as planning guides; projects should only be undertaken by authorised designer and professionals.

5/16" RAPID® fullthread cylinder head

T-drive (T40), cylinder head, single thread, compressor, from 4-3/4" to 15-3/4" with full tip, from 17-3/4" with half tip, YellWin 500+ coating



D_{nom}	D	D_H	D_r	N_a	N_u	$F_{yb,spec}^{1)}$
in (mm)	in	in	in	lbf	lbf	psi
5/16" (8)	0.315	0.402	0.205	1,920	2,890	209,300

	$L_{emb,w}$	W_{90}
	in	lbf/in
$SG_{NDS} = 0.42$	≥ 1.89	160
$SG_{NDS} = 0.50$	≥ 1.89	181
LVL of DFir* $SG_{eg} = 0.50$	≥ 1.89	197

* acc. to ESR-1040

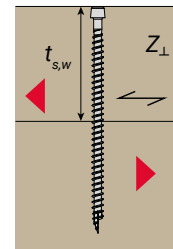
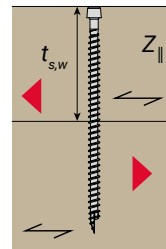
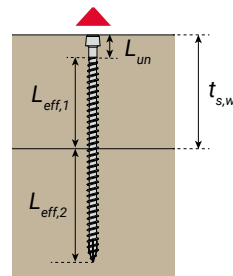
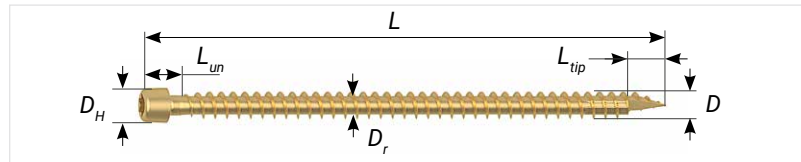

$D_{nom} = 5/16"$ (8 mm)				AXIAL 90° ²⁾				LATERAL ³⁾				
				WOOD-TO-WOOD				WOOD-TO-WOOD				
L		L_{un}	L_{tip}	$t_{s,w}$ 0.5 · L	min { $W_{90}; N_a$ }			$t_{s,w}$ 0.5 · L	$Z_{ }$ ⁴⁾		$Z_{\perp,m}$	
					SG_{NDS} 0.42	SG_{NDS} 0.50	LVL of DFir* $SG_{eg} = 0.50$		SG_{NDS} 0.42	SG_{NDS} 0.50	SG_{NDS} 0.42	SG_{NDS} 0.50
in	(mm)	in	in	in	lbf	lbf	lbf	in	lbf	lbf	lbf	lbf
4-3/4"	120	0.394	0.323	2.36	315	356	388	-	-	-	-	-
5-1/2"	140	0.394	0.323	2.76	378	428	465	-	-	-	-	-
6-1/4"	160	0.394	0.323	3.15	441	499	543	-	-	-	-	-
7-1/8"	180	0.394	0.323	3.54	504	570	620	3.54	252	296	202	237
7-7/8"	200	0.394	0.323	3.94	567	641	698	3.94	252	296	202	237
8-5/8"	220	0.394	0.323	4.33	630	713	776	4.33	252	296	202	237
9-1/2"	240	0.394	0.323	4.72	693	784	853	4.72	252	296	202	237
10-1/4"	260	0.394	0.323	5.12	756	855	931	5.12	252	296	202	237
11"	280	0.394	0.323	5.51	819	926	1008	5.51	252	296	202	237
11-3/4"	300	0.394	0.323	5.91	882	998	1086	5.91	252	296	202	237
12-3/4"	325	0.394	0.323	6.40	961	1087	1183	6.40	252	296	202	237
13-3/4"	350	0.394	0.323	6.89	1039	1176	1280	6.89	252	296	202	237
14-3/4"	375	0.394	0.323	7.38	1118	1265	-	7.38	252	296	202	237
15-3/4"	400	0.394	0.323	7.87	1197	1354	-	7.87	252	296	202	237
17-3/4"	450	0.906	0.433	8.86	1272	1439	-	8.86	252	296	202	237
19-5/8"	500	0.906	0.433	9.84	1430	1618	-	9.84	252	296	202	237
23-5/8"	600	0.906	0.433	11.81	1745	1920	-	11.81	252	296	202	237

¹⁾ Minimum specified bending yield strength, determined in acc. with ASTM F1575 using D_r .
²⁾ For axial capacity determine the minimum of the corresponding adjusted values, min{ $W_{90}; N_a$ }; in case of $\alpha < 90^\circ$ apply factor R_α ;
³⁾ Reference lateral design values for single shear connection with loading parallel to grain (dowel bearing strength $F_{e||}$) and perpendicular to grain ($F_{e\perp}$) according to NDS; determined with D_r .

Typos and printing errors reserved. The values stated in combination with geometric requirements, instruction and all further notes are meant to serve as planning guides; projects should only be undertaken by authorised professionals.

5/16" RAPID[®] fullthread cylinder head

T-drive (T40), cylinder head, single thread, compressor, from 4-3/4" to 15-3/4" with full tip, from 17-3/4" with half tip, YellWin 500+ coating



D_{nom}	D	D_H	D_r	N_a	N_u	$F_{yb,spec}$ ¹⁾
in (mm)	in	in	in	lbf	lbf	psi
5/16" (8)	0.315	0.402	0.205	1,920	2,890	209,300

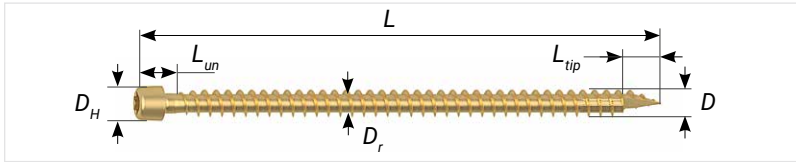

	$L_{emb,w}$	W_{90}
	in	lbf/in
$SG_{NDS} = 0.42$	≥ 1.89	160
$SG_{NDS} = 0.50$	≥ 1.89	181
LVL of DFir* $SG_{eg} = 0.50$	≥ 1.89	197

* acc. to ESR-1040

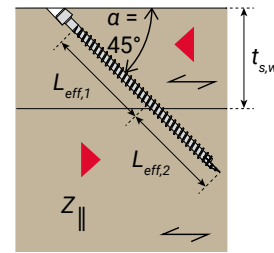
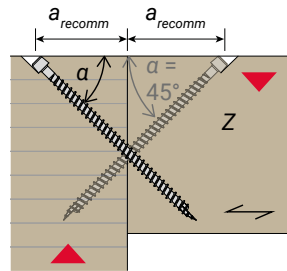

$D_{nom} = 5/16"$ (8 mm)		MAINLY AXIAL 45° ²⁾				MAINLY AXIAL 45° ⁴⁾			
		1 SYMMETRIC SCREW PAIR				WOOD-TO-WOOD with $\min\{L_{eff,1}, L_{eff,2}\}$			
L		a_{recomm}	Z			$t_{s,w}$ $0.5 \cdot L$	$Z_{ } = \min\{W_{45}, N_a\} \cdot \cos 45^\circ$		
			SG_{NDS} 0.42	SG_{NDS} 0.50	LVL of DFir* $SG_{eg} = 0.50$		SG_{NDS} 0.42	SG_{NDS} 0.50	LVL of DFir* $SG_{eg} = 0.50$
in	(mm)	in	lbf	lbf	lbf	in	lbf	lbf	
4-3/4"	120	-	-	-	-	1.97	225	255	277
5-1/2"	140	-	-	-	-	1.97	225	255	277
6-1/4"	160	-	-	-	-	2.36	283	320	348
7-1/8"	180	-	-	-	-	2.36	283	320	348
7-7/8"	200	-	-	-	-	2.36	283	320	348
8-5/8"	220	10.5D ³⁾	841 ³⁾	951 ³⁾	1035	3.15	397	449	489
9-1/2"	240	11.5D ³⁾	932 ³⁾	1054 ³⁾	1148	3.15	397	449	489
10-1/4"	260	12.5D ³⁾	1003 ³⁾	1134 ³⁾	1234	3.15	397	449	489
11"	280	13.5D ³⁾	1073 ³⁾	1214 ³⁾	-	3.94	512	579	630
11-3/4"	300	14.0D ³⁾	1162 ³⁾	1314 ³⁾	-	3.94	512	579	630
12-3/4"	325	15.5D ³⁾	1254 ³⁾	1419 ³⁾	-	4.72	627	709	772
13-3/4"	350	16.5D ³⁾	1365 ³⁾	1544 ³⁾	-	4.72	627	709	772
14-3/4"	375	17.5D ³⁾	1476 ³⁾	1670 ³⁾	-	5.51	741	839	913
15-3/4"	400	18.5D ³⁾	1575 ³⁾	1781 ³⁾	-	5.51	741	839	913
17-3/4"	450	21.0D ³⁾	1707 ³⁾	1931 ³⁾	-	6.30	803	909	989
19-5/8"	500	23.0D	1890	2138	-	7.09	918	1038	-
23-5/8"	600	27.5D	2303	2605	-	7.87	1032	1168	-

¹⁾ Minimum specified bending yield strength, determined in acc. with ASTM F1575 using D_r .
²⁾ Recommended distance from the end to the screw axis. To follow the distance requirements according to ICC-ESR-4549 with $a_{end,CG} \geq 10D$ in a connection of a main and a secondary beam with a symmetric screw pair requires screw lengths over or equal to 58D with appropriate wood member dimensions. The capacity result of a screw loaded in tension and one loaded in compression. Note, the characteristic buckling capacity $k_c \cdot N_{plk}$ is determined according to ETA-12/0373:2022 considers a lower bending yield strength than according to ICC-ESR-4549. Z is determined as $(\min\{W_{45}, N_a\} + \min\{W_{45}, N_a\} \cdot (k_c \cdot N_{plk}) \cdot \sin 45^\circ)$ with $k_c \cdot N_{plk} = 2,713$ lbf for $SG_{NDS} = 0.42$, $k_c \cdot N_{plk} = 2,843$ lbf for $SG_{NDS} = 0.50$ and $k_c \cdot N_{plk} = 2,872$ lbf for LVL of DFir with $SG_{eg} = 0.50$.
³⁾ Given values for a_{recomm} and design values base on requirements according to ETA-12/0373:2022.

⁴⁾ On responsibility of the qualified designer, friction can be considered as proposed in ETA-12/0373:2022 by a friction coefficient of $\mu = 0.30$. In this case, tabulated values can be justified to rely on friction with factor $(\sin 45^\circ + \mu \cdot \cos 45^\circ) / \sin 45^\circ = 1.30$.

These applications are not covered by ICC-ESR-4549: IT IS ON THE RESPONSIBILITY OF THE QUALIFIED DESIGNER TO APPLY INCLINED SCREWS, TO CHOSE ADEQUAT DISTANCES, TO CONSIDER SCREWS LOADED IN COMPRESSION AND FRICTION LOADS, AS WELL AS TO JUSTIFY THE CONNECTION GEOMETRY, ALL TO THE SATISFACTION OF THE CODE OFFICIAL.

Typos and printing errors reserved. The values stated in combination with geometric requirements, instruction and all further notes are meant to serve as planning guides; projects should only be undertaken by authorised designer and professionals.

3/8" RAPID[®] fullthread cylinder head

T-drive (T50), cylinder head, single thread, compressor, half tip, YellWin 500+ coating



D_{nom}	D	D_H	D_r	N_a	N_u	$F_{yb,spec}^{1)}$
in (mm)	in	in	in	lbf	lbf	psi
3/8" (10)	0.394	0.528	0.240	3,490	5,240	206,400

	$L_{emb,w}$	W_{90}
	in	lbf/in
$SG_{NDS} = 0.42$	≥ 2.36	182
$SG_{NDS} = 0.50$	≥ 2.36	224
LVL of DFir* $SG_{eg} = 0.50$	≥ 2.36	197

* acc. to ESR-1040

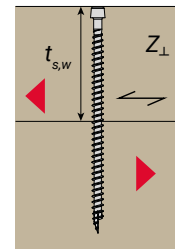
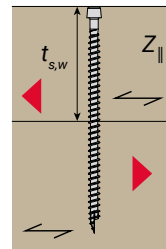
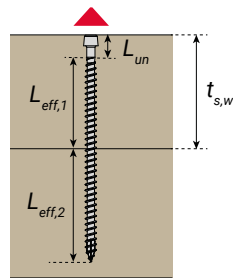
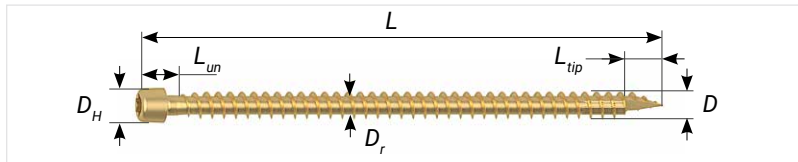

$D_{nom} = 3/8"$ (10 mm)				AXIAL 90° ²⁾					LATERAL ³⁾				
				WOOD-TO-WOOD					WOOD-TO-WOOD				
L		L_{un}	L_{tip}	$t_{s,w}$ 0.5 · L	min { $W_{90}; N_a$ }			$t_{s,w}$ 0.5 · L	$Z_{ }$ ⁴⁾		$Z_{\perp,m}$		
					SG_{NDS} 0.42	SG_{NDS} 0.50	LVL of DFir* $SG_{eg} = 0.50$		SG_{NDS} 0.42	SG_{NDS} 0.50	SG_{NDS} 0.42	SG_{NDS} 0.50	
in	(mm)	in	in	in	lbf	lbf	lbf	in	lbf	lbf	lbf	lbf	
7-7/8"	(200)	0.472	0.512	3.94	631	776	683	3.94	302	355	242	284	
9-1/2"	(240)	0.472	0.512	4.72	774	953	838	4.72	302	355	242	284	
10-1/4"	(260)	0.472	0.512	5.12	846	1041	915	5.12	302	355	242	284	
11"	(280)	0.472	0.512	5.51	917	1129	993	5.51	302	355	242	284	
11-3/4"	(300)	0.472	0.512	5.91	989	1217	1070	5.91	302	355	242	284	
12-3/4"	(325)	0.945	0.512	6.40	992	1221	1074	6.40	302	355	242	284	
13-3/4"	(350)	0.945	0.512	6.89	1082	1332	1171	6.89	302	355	242	284	
14-3/4"	(375)	0.945	0.512	7.38	1172	1442	-	7.38	302	355	242	284	
15-3/4"	(400)	0.945	0.512	7.87	1261	1552	-	7.87	302	355	242	284	
17-3/4"	(450)	0.945	0.512	8.86	1440	1773	-	8.86	302	355	242	284	
19-5/8"	(500)	0.945	0.512	9.84	1619	1993	-	9.84	302	355	242	284	
23-5/8"	(600)	0.945	0.512	11.81	1978	2434	-	11.81	302	355	242	284	
27-5/8"	(700)	0.945	0.512	13.78	2336	2875	-	13.78	302	355	242	284	
31-1/2"	(800)	0.945	0.512	15.75	2694	3316	-	15.75	302	355	242	284	
39-3/8"	(1000)	0.945	0.512	19.69	3411	3490	-	19.69	302	355	242	284	

¹⁾ Minimum specified bending yield strength, determined in acc. with ASTM F1575 using D_r .

²⁾ For axial capacity determine the minimum of the corresponding adjusted values, min{ $W; N$ }; in case of $\alpha < 90^\circ$ apply factor R_α ;

³⁾ Reference lateral design values for single shear connection with loading parallel to grain (dowel bearing strength $F_{e||}$) and perpendicular to grain ($F_{e\perp}$) according to NDS; determined with D_r .

Typos and printing errors reserved. The values stated in combination with geometric requirements, instruction and all further notes are meant to serve as planning guides; projects should only be undertaken by authorised professionals.

3/8" RAPID[®] fullthread cylinder head

T-drive (T50), cylinder head, single thread, compressor, half tip, YellWin 500+ coating



D_{nom}	D	D_H	D_r	N_a	N_u	$F_{y,spec}^{1)}$
in (mm)	in	in	in	lbf	lbf	psi
3/8" (10)	0.394	0.528	0.240	3,490	5,240	206,400

	$L_{emb,w}$	W_{90}
	in	lbf/in
$SG_{NDS} = 0.42$	≥ 2.36	182
$SG_{NDS} = 0.50$	≥ 2.36	224
LVL of DFir* $SG_{eg} = 0.50$	≥ 2.36	197

* acc. to ESR-1040

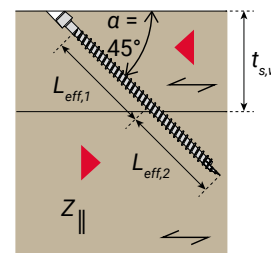
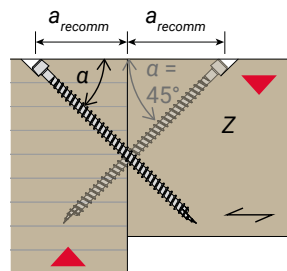
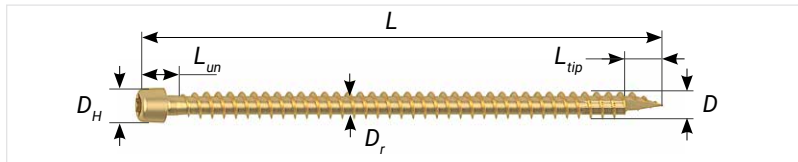

$D_{nom} = 3/8"$ (10 mm)		MAINLY AXIAL 45° ²⁾				MAINLY AXIAL 45° ⁴⁾			
		1 SYMMETRIC SCREW PAIR				WOOD-TO-WOOD with $\min\{L_{eff,1}, L_{eff,2}\}$			
		L	a_{recomm}	Z			$t_{s,w}$ $0.5 \cdot L$	$Z_{\parallel} = \min\{W_{45} \cdot N_a\} \cdot \cos 45^\circ$	
SG_{NDS} 0.42	SG_{NDS} 0.50			LVL of DFir* $SG_{eg} = 0.50$	SG_{NDS} 0.42	SG_{NDS} 0.50		LVL of DFir* $SG_{eg} = 0.50$	
in	(mm)	in	lbf	lbf	lbf	in	lbf	lbf	
7-7/8"	(200)	-	-	-	-	2.36	305	375	330
9-1/2"	(240)	-	-	-	-	2.36	305	375	330
10-1/4"	(260)	-	-	-	-	2.36	305	375	330
11"	(280)	-	-	-	-	2.36	305	375	330
11-3/4"	(300)	11.5D ³⁾	1327 ³⁾	1634 ³⁾	-	3.15	435	536	471
12-3/4"	(325)	12.5D ³⁾	1348 ³⁾	1659 ³⁾	-	3.15	380	468	411
13-3/4"	(350)	13.5D ³⁾	1479 ³⁾	1820 ³⁾	-	4.72	641	789	694
14-3/4"	(375)	14.0D ³⁾	1544 ³⁾	1900 ³⁾	-	3.94	510	628	553
15-3/4"	(400)	15.0D ³⁾	1674 ³⁾	2061 ³⁾	-	5.51	771	949	835
17-3/4"	(450)	17.0D ³⁾	1935 ³⁾	2382 ³⁾	-	4.72	641	789	694
19-5/8"	(500)	18.5D ³⁾	2131 ³⁾	2623 ³⁾	-	4.72	641	789	694
23-5/8"	(600)	22.0D ³⁾	2588 ³⁾	3185 ³⁾	-	5.51	771	949	835
27-5/8"	(700)	25.5D	3045	3747	-	6.30	902	1110	976
31-1/2"	(800)	29.0D	3502	4310	-	7.09	1032	1270	-
39-3/8"	(1000)	36.5D	4480	4936	-	7.87	1163	1431	-

¹⁾ Minimum specified bending yield strength, determined in acc. with ASTM F1575 using D_r .
²⁾ Recommended distance from the end to the screw axis. To follow the distance requirements according to ICC-ESR-4549 with $a_{end,CG} \geq 10D$ in a connection of a main and a secondary beam with a symmetric screw pair requires screw lengths over or equal to $58D$ with appropriate wood member dimensions. The capacity result of a screw loaded in tension and one loaded in compression. Note, the characteristic buckling capacity $k_c \cdot N_{plk}$ is determined according to ETA-12/0373:2022 considers a lower bending yield strength than according to ICC-ESR-4549. Z is determined as $(\min\{W_{45} \cdot N_a\} + \min\{W_{45} \cdot N_a\} \cdot (k_c \cdot N_{plk})) \cdot \sin 45^\circ$ with $k_c \cdot N_{plk} = 3,789$ lbf for $SG_{NDS} = 0.42$, $k_c \cdot N_{plk} = 3,951$ lbf for $SG_{NDS} = 0.50$ and $k_c \cdot N_{plk} = 4,003$ lbf for LVL of DFir with $SG_{eg} = 0.50$.
³⁾ Given values for a_{recomm} and design values base on requirements according to ETA-12/0373:2022.

⁴⁾ On responsibility of the qualified designer, friction can be considered as proposed in ETA-12/0373:2022 by a friction coefficient of $\mu = 0.30$. In this case, tabulated values can be justified to rely on friction with factor $(\sin 45^\circ + \mu \cdot \cos 45^\circ) / \sin 45^\circ = 1.30$.

These applications are not covered by ICC-ESR-4549: IT IS ON THE RESPONSIBILITY OF THE QUALIFIED DESIGNER TO APPLY INCLINED SCREWS, TO CHOSE ADEQUAT DISTANCES, TO CONSIDER SCREWS LOADED IN COMPRESSION AND FRICTION LOADS, AS WELL AS TO JUSTIFY THE CONNECTION GEOMETRY, ALL TO THE SATISFACTION OF THE CODE OFFICIAL.
 Typos and printing errors reserved. The values stated in combination with geometric requirements, instruction and all further notes are meant to serve as planning guides; projects should only be undertaken by authorised designer and professionals.

1/2" RAPID® fullthread T-Lift

T-drive (T40) & hexagonal drive (SW 17), Dual head, single thread, compressor, full tip, BlueWin coating



D_{nom}	D	D_H	D_r	N_a	N_u	$F_{yb,spec}^{1)}$
in (mm)	in	in	in	lbf	lbf	psi
1/2" (12)	0.472	0.669	0.268	3,880	5,820	193,300

	$L_{emb,w}$	W_{90}
	in	lbf/in
$SG_{NDS} = 0.42$	≥ 2.83	223
$SG_{NDS} = 0.50$	≥ 2.84	251
LVL of DFir* $SG_{eg} = 0.50$	≥ 2.84	224

* acc. to ESR-1040

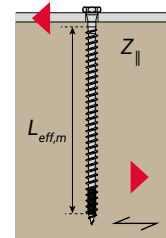
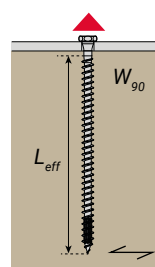
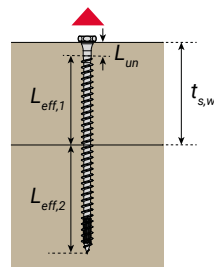
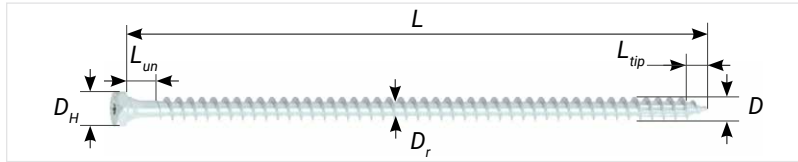

$D_{nom} = 1/2"$ (12 mm)				AXIAL 90° ²⁾								LATERAL ³⁾	
				WOOD-TO-WOOD				STEEL-TO-WOOD ⁴⁾				STEEL-TO-WOOD ⁴⁾	
L	L_{un}	L_{tip}	$t_{s,w}$ 0.5·L	min { $W_{90}; N_a$ }			$L_{eff} = L - L_{un}$ ⁴⁾	min { $W_{90}; N_a$ }			$Z_{ }$ ⁴⁾		
				SG_{NDS} 0.42	SG_{NDS} 0.50	LVL of DFir* $SG_{eg} = 0.50$		SG_{NDS} 0.42	SG_{NDS} 0.50	LVL of DFir* $SG_{eg} = 0.50$	SG_{NDS} 0.42	SG_{NDS} 0.50	
in	(mm)	in	in	lbf	lbf	lbf	in	lbf	lbf	lbf	lbf	lbf	
2-3/8"	(60)	0.472	0.441	-	-	-	-	-	-	-	-	-	-
3-1/8"	(80)	0.472	0.441	-	-	-	-	-	-	-	-	-	-
4"	(100)	0.591	0.441	-	-	-	3.35	746	840	750	433	467	
4-3/4"	(120)	0.591	0.441	-	-	-	4.13	922	1038	926	433	467	
5-1/2"	(140)	0.591	0.441	-	-	-	4.92	1097	1235	1102	433	467	
6-1/4"	(160)	0.591	0.441	-	-	-	5.71	1273	1433	1279	433	467	
7-1/8"	(180)	0.591	0.441	3.54	658	741	661	6.50	1449	1631	1455	433	467
8-5/8"	(220)	0.591	0.441	4.33	834	939	838	8.07	1800	2026	-	433	467
11-3/4"	(300)	0.591	0.441	5.91	1185	1334	1190	11.22	2502	2816	-	433	467
15"	(380)	0.591	0.441	7.48	1536	1729	-	14.37	3205	3607	-	433	467

¹⁾ Minimum specified bending yield strength, determined in acc. with ASTM F1575 using D_r .
²⁾ For axial capacity determine the minimum of the corresponding adjusted values, min{ $W; N$ }; in case of $\alpha < 90^\circ$ apply factor R_α .
³⁾ Reference lateral design values for single shear connection with loading parallel to grain (dowel bearing strength $F_{e||}$) and perpendicular to grain ($F_{e\perp}$) according to NDS; determined with D_r .

⁴⁾ Assumed steel plate thickness $t_{s,s} = 0.236$ inch; the steel plate has to be verified separately and according to corresponding steel standards.
 Typos and printing errors reserved. The values stated in combination with geometric requirements, instruction and all further notes are meant to serve as planning guides; projects should only be undertaken by authorised professionals.

1/2" RAPID[®] fullthread T-Lift

T-drive (T40) & hexagonal drive (SW 17), Dual head, single thread, compressor, full tip, BlueWin coating



D_{nom}	D	D_H	D_r	N_a	N_u	$F_{yb,spec}^{1)}$
in (mm)	in	in	in	lbf	lbf	psi
1/2" (12)	0.472	0.669	0.268	3,880	5,820	193,300

	$L_{emb,w}$	W_{90}
	in	lbf/in
$SG_{NDS} = 0.42$	≥ 2.83	223
$SG_{NDS} = 0.50$	≥ 2.84	251
LVL of DFir* $SG_{eg} = 0.50$	≥ 2.84	224

* acc. to ESR-1040

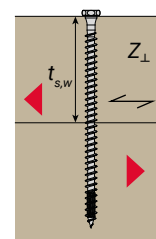
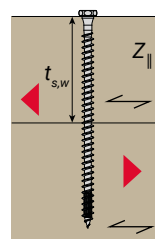
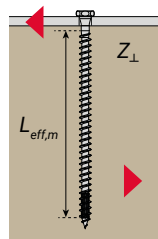
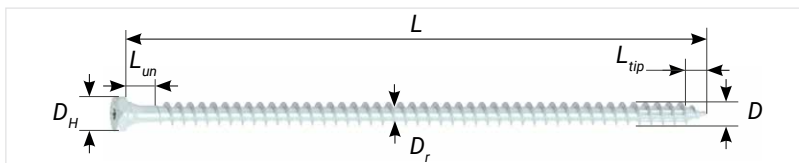

$D_{nom} = 1/2"$ (12 mm)		LATERAL ³⁾						
		STEEL-TO-WOOD			WOOD-TO-WOOD			
L		$Z_{\perp}^{4)}$		$t_{s,w}$ $0.5 \cdot L$	Z_{\parallel}		$Z_{\perp,m}$	
		SG_{NDS} 0.42	SG_{NDS} 0.50		SG_{NDS} 0.42	SG_{NDS} 0.50	SG_{NDS} 0.42	SG_{NDS} 0.50
in	(mm)	lbf	lbf	in	lbf	lbf	lbf	lbf
2-3/8"	(60)	-	-	-	-	-	-	-
3-1/8"	(80)	-	-	-	-	-	-	-
4"	(100)	284	333	-	-	-	-	-
4-3/4"	(120)	298	333	-	-	-	-	-
5-1/2"	(140)	298	333	-	-	-	-	-
6-1/4"	(160)	298	333	-	-	-	-	-
7-1/8"	(180)	298	333	3.543	391	426	285	318
8-5/8"	(220)	298	333	4.331	391	426	285	318
11-3/4"	(300)	298	333	5.906	391	426	285	318
15"	(380)	298	333	7.480	391	426	285	318

¹⁾ Minimum specified bending yield strength, determined in acc. with ASTM F1575 using D_r .

²⁾ For axial capacity determine the minimum of the corresponding adjusted values, $\min\{W; N\}$; in case of $\alpha < 90^\circ$ apply factor R_α ; Reference head pull through and withdrawal design values for SG_{NDS} between 0.42 and 0.55 can be determined by linear interpolation.

³⁾ Reference lateral design values for single shear connection with loading parallel to grain (dowel bearing strength F_{\parallel}) and perpendicular to grain (F_{\perp}) according to NDS;

determined with D_r .

⁴⁾ Assumed steel plate thickness $t_{s3} = 0.236$ inch; the steel plate has to be verified separately and according to corresponding steel standards.

Typos and printing errors reserved. The values stated in combination with geometric requirements, instruction and all further notes are meant to serve as planning guides; projects should only be undertaken by authorised professionals.

Idaho Central Credit Union Arena



The 4,000-seat arena is the new home for the Vandal's varsity basketball teams and a gathering place for a variety of school and community events. One of the many unique features of this project is the efficient timber/steel portal frame that spans 120' to allow for viewing from the secondary seating at the practice rink. The entire frame was pre-assembled on site into three large components to minimize work at height. Complex timber engineering was required to design the thrust connection between beam and column to transfer over 450,000 lbs. of compression. The kingpost trusses span over 150 ft. across the main

arena. One of the key challenges was installation of these heavy elements with a crane in the bowl. A parametric model of the trusses was created using genetic algorithms to perform a structural optimization on the trusses, while respecting aesthetic numerous objectives. This created structural efficiency and, importantly, reduced weights of the prefabricated pieces. This also allowed the project budget to be maintained. Due to the high forces acting on the beams and supports, special, high-quality RAPID® fullthread screws were also used.



Photos © Structure Craft

Facts & Figures:

Customer:
University of Idaho

Architect:
Opsis Architecture, USA

Location:
Moscow, ID, USA

Structural Engineer & Builder:
Structure Craft, Canada

Completion:
2021

Lookout tower on the Pyramidenkogel



At a height of 100 meters, the observation tower on the Pyramidenkogel is the highest wooden observation tower in the world. A successful collaboration between Rubner Holzbau Ober-Grafendorf and Schmid Schrauben Hainfeld.

The construction consists of 500 m³ of glulam and 1,000 m² of cross-laminated timber. The tower is given its unusual shape by 16 solid and elliptically arranged larch glulam columns, which spiral upwards.

The structure stretches over 10 levels, above which there are two outdoor platforms offering a 360° view.

The highlight is the skybox, which has been designed with panoramic windows. This level can be reached either via steps or by elevator. The 120-meter-long slide down to the first floor can also be used.

The assembly was carried out by Rubner Holzbau. The rapid construction of the viewing tower was made possible by precise prefabrication in the production facility in Obergrafendorf. Screws from Schmid Schrauben Hainfeld were used for this. This prefabrication enables rapid construction progress and consequently a corresponding cost advantage.



Photos © Rubner Holzbau

Facts & Figures:

Customer:
Pyramidenkogel Infrastruktur GmbH & Co KG

Architect:
Klaura, Kaden + Partner, Austria

Location:
Austria

Structural Engineer & Builder:
Rubner Holzbau, Austria

Completion:
2013

Fyrtornet

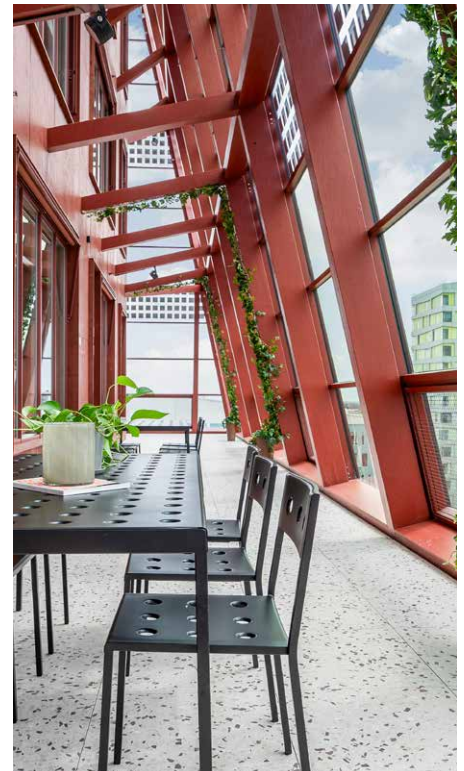

Fyrtornet is an innovative office building in the Hyllie district of Malmö and part of the “Embassy of Sharing” project. It will be completed in 2024 as Sweden’s tallest wooden building with 11 floors. The sustainable design is based on wood and integrates solar energy and geothermal energy. With a focus on circular economy and the global goals of Agenda 2030, Fyrtornet offers flexible workspaces, a library, green terraces and energy-efficient systems. Wood as a building material plays a central role in this project. 1,640 m³ of cross-laminated timber (CLT) and 1,030 m³ of glulam were used to build the structure.

The timber, project planning, statics, work planning and prefabrication were provided by our partner Binderholz and b_project. Wood not only offers stability, but also contributes to minimizing the CO2 footprint. The use of prefabricated timber construction elements meant that the construction time could be significantly reduced. Our RAPID® screws, which were perfectly suited to the project thanks to their outstanding technical values, such as load-bearing capacity and small edge distances, also made a significant contribution to the realization of the project.



Binderholz, Photos © Granitor

Facts & Figures:

Customer:
Granitor Projects AB

Architect:
Wingårdhs, Sweden

Location:
Sweden

Timber construction:
Binderholz, Austria

Completion:
2024

World of Volvo

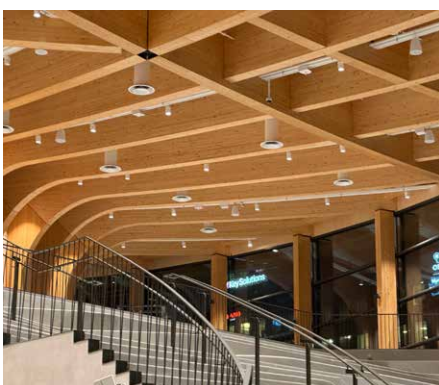

The “World of Volvo” in Gothenburg is a pioneering construction project that impresses with its technical refinement and innovative use of wood. Developed by WIEHAG Holding GmbH a long-standing partner of Schmid Schrauben Hainfeld, in close cooperation with renowned architects and engineers, this building represents a perfect symbiosis of aesthetics and functionality.

A technical highlight of the “World of Volvo” is its impressive wood structure, which not only provides a breathtaking architectural appearance, but also meets the highest demands for load-bearing capacity

and safety. Precise planning and implementation of this structure was made possible by the expertise of Ramboll, a world-leading engineering and consulting company offering innovative solutions for complex construction projects.

For the new Stockholm landmark, WIEHAG supplied 6,000 m³ BSH: 3,600 m³ for pillars and beams, 2,400 m³ for roof and ceiling elements. The three largest timber beams measure 34 m in length each.

In addition to the visitor center, the World of Volvo will also offer space for events and culinary experiences.



Photos © WIEHAG Holding GmbH

Facts & Figures:

Customer:
AB Volvo and Volvo Cars

Architect:
Henning Larsen

Location:
Sweden

Wooden roof construction and engineering:
WIEHAG GmbH

Completion:
2023

RAPID® Secure: screw-in tool

The RAPID® Secure screw-in tool represents a completely new technology for secure screwing in wood construction.

With this solution, long RAPID® wood drilling screws can be screwed securely and quickly with all screwdrivers (for 1/2" drill chuck size) without any problems. The screw head is held securely in place and is firmly connected with the RAPID® Secure. There is no way for the bit to slip off and no need to press down.

The RAPID® Secure screw-in tool makes screwing in RAPID® wood drilling screws extremely safe and easy. The tool can be used with conventional screwdrivers and gives your workers security even in inconvenient screwing positions.



BENEFITS FROM USING THE RAPID® SECURE:

- > Increased work safety for employees
- > After being locked into place, the screw cannot be loosened and fits tightly on the bit - no pressing down while screwing in and less wear - bit holds for much longer
- > Easier to screw in difficult and dangerous work positions and situations

USE THE RAPID® SECURE WITH RAPID® SCREWS:

RAPID® SECURE L, T 40	5/16" RAPID® countersunk head 5/16" RAPID® cylinder head 3/8" RAPID® Dual
RAPID® SECURE L, special bit T50	3/8" RAPID® cylinder head
RAPID® SECURE XL, T 40	5/16" RAPID® washer head 5/16" RAPID® SuperSenkFix 1/2" RAPID® Dual 1/2" RAPID® T-Lift
RAPID® SECURE XL, T 50	3/8" RAPID® countersunk head 3/8" RAPID® SuperSenkFix 1/2" RAPID® countersunk head



SCAN TO WATCH
THE VIDEO



USER MANUAL
RAPID® SECURE L



USER MANUAL
RAPID® SECURE XL



Responsibility for the future



FAIR PLAY

We naturally comply with statutory regulations. They are many times more stringent than those of other regions regarding the handling of carbon dioxide, energy, waste and chemicals.



SMALL CARBON FOOTPRINT

Our partners are primarily local European raw material suppliers. This means that our transport routes are shorter than if we were to import raw materials on container ships, which cause high levels of harmful emissions



SOCIAL STANDARDS

It is self-evident that the exploitation of workers and child labour have no place in an Austrian company. However, we ensure that these and other social standards are adhered to in the companies of our suppliers and partners as well.



HIGHEST PRODUCT QUALITY

Our premium products make it possible to implement more efficient application solutions with fewer screws, which helps to conserve resources. Furthermore, our high-quality screws ensure a longer service life along with faster and easier processing.



RECYCLING

Thanks to the good anti-friction coating and geometry of our premium products, they can be removed from the timber without a trace. This allows individual beams and joists to be reassembled into new structures, thus saving resources.



ENERGY-SAVING PRODUCTION

The switch to electrically operated forklifts and LED lights, along with new energy-saving technologies and machinery in production and heat recovery in the hardening process, has helped our production to become more environmentally friendly.



HEALTH IN THE WORKPLACE

We are mindful of our employees' health and rely on healthy, environmentally friendly chemicals and raw materials wherever possible. For example, we have established the use of Cr(VI)-free corrosion protection in our Premium RAPID® screws.



CONTINUAL IMPROVEMENT

We strive to continually improve our carbon footprint. The ISO 50001 energy management system and the ISO 14001 environmental management system help to make sure of this. Suggestions to improve each individual employee's work routine are actively communicated on an ongoing basis.



ONGOING ANALYSES OF ENERGY FLOW

We analyse our energy flow on an ongoing basis, as well as resource consumption, so that we can quickly counteract "energy guzzlers" or wastage. At the same time, we also work actively on developments and optimisations in the area of energy recovery from production.





Experience

We have been specialists in the manufacture of wood construction screws for over 180 years.



Sustainability

We take care of our environment and manufacture according to ISO 14001 and ISO 50001.



Always available

Our warehouse is always stocked with our extensive range.



Your screw - your brand

We manufacture screws exactly according to your wishes.



Special hardening

Our screws are viscoplastic and bendable by at least 45° - elastic and high-strength.



Service orientation

Whether with calculations, expertise or experience - we are there for our customers.



Statics

Our screws have above-average mechanical values for pull-out and head pull-through.



Safety

Our screws are approved according to ETA 12/0373 and ICC-ESR-4549.



Highest quality

We manufacture according to ISO 9001 and are externally monitored by Holzfor-schung Austria.



Schmid Schrauben Hainfeld GmbH

Landstal 10 | A-3170 Hainfeld | T +43 (0)2764 2652 | F +43 (0)2764 3149 | E info@schrauben.at

